

R Y T E C

# Spiral LH - HZ

---

## Installation Manual



P.O. Box 403, One Cedar Parkway, Jackson, WI 53037  
Phone 262-677-9046 Fax 262-677-2058  
Rytec E-mail: [Helpdesk@rytecdoors.com](mailto:Helpdesk@rytecdoors.com), Parts E-mail: [parts@rytecdoors.com](mailto:parts@rytecdoors.com)  
[Revision: September 19<sup>th</sup> 2013, 1070903-0, © Rytec Corporation 2009]



## Table of Contents

<b>APPROVAL DADE COUNTY.....</b>	<b>1</b>
<b>NOTICE OF ACCEPTANCE.....</b>	<b>2</b>
<b>DOOR DIMENSIONS.....</b>	<b>4</b>
<b>INTRODUCTION.....</b>	<b>8</b>
<b>DOOR SERIAL NUMBER(S).....</b>	<b>8</b>
<b>HOW TO USE MANUAL.....</b>	<b>8</b>
<b>INSTALLATION.....</b>	<b>9</b>
<b>MATERIAL, TOOLS, AND EQUIPMENT.....</b>	<b>9</b>
<b>ADDITIONAL REQUIREMENTS.....</b>	<b>9</b>
<b>TYPICAL INSTALLATION.....</b>	<b>10</b>
<b>MINIMUM CONCRETE REQUIREMENT.....</b>	<b>10</b>
<b>ANCHORING METHOD.....</b>	<b>10</b>
<b>DETAILS - TOP OF SIDE COLUMN.....</b>	<b>11</b>
<b>BASE PLATE - ANCHOR LOCATIONS.....</b>	<b>11</b>
<b>UNCRATING.....</b>	<b>11</b>
<b>LOCATE CENTERLINE OF DOOR OPENING.....</b>	<b>12</b>
<b>LOCATING SIDE COLUMNS.....</b>	<b>12</b>
<b>SIDE COLUMNS.....</b>	<b>13</b>
<b>REAR SPREADER.....</b>	<b>15</b>
<b>CONSOLE ASSEMBLY.....</b>	<b>16</b>
<b>CONNECTION SHAFT.....</b>	<b>18</b>
<b>MOTOR DRIVE BELT.....</b>	<b>19</b>
<b>SPRING PACK AND DRIVE BELT.....</b>	<b>19</b>
<b>SAMPLE PACKING SHEET.....</b>	<b>22</b>

## Table of Contents

<b>Drive Belt and Guide Pulley System.....</b>	<b>23</b>
<b>Console Guide Pulley Trolley Adjustment.....</b>	<b>24</b>
CONSOLE – SINGLE ADJUSTING SCREW (L-SERIES).....	24
CONSOLE – DUAL ADJUSTING SCREWS (S-SERIES).....	25
<b>HORIZONTAL GUIDE RAILS.....</b>	<b>26</b>
<b>DOOR PANEL.....</b>	<b>27</b>
<b>BRAKE RELEASE.....</b>	<b>28</b>
<b>DOOR PANEL TO DRIVE BELT L-SIZE.....</b>	<b>29</b>
<b>DOOR PANEL TO DRIVE BELT S-SIZE.....</b>	<b>30</b>
<b>PHOTO EYES.....</b>	<b>31</b>
<b>WIRELESS ANTENNA BRACKET.....</b>	<b>34</b>
<b>CONTROL SYSTEM.....</b>	<b>35</b>
<b>DRIVE MOTOR TO CONTROL PANEL.....</b>	<b>36</b>
<b>BRAKE RELEASE SENSOR TO CONTROL PANEL.....</b>	<b>36</b>
<b>FACTORY-INSTALLED PHOTO EYES TO CONTROL PANEL.....</b>	<b>36</b>
CUSTOMER-INSTALLED PHOTO EYES TO CONTROL PANEL.....	37
<b>ACTIVATORS.....</b>	<b>37</b>
<b>OPERATING CONTROL SYSTEM.....</b>	<b>38</b>
Modes of Operation.....	38
INITIAL START-UP.....	38
<b>FINAL ADJUSTMENTS.....</b>	<b>40</b>
LEVELING DOOR PANEL.....	40
TESTING REVERSING EDGE.....	42
TESTING PHOTO EYES.....	42
<b>INSTALLING COVERS.....</b>	<b>43</b>
<b>FINAL CHECK.....</b>	<b>44</b>

**APPROVAL DADE COUNTY**

The following information is from the Building Code Compliance Office in Miami-Dade County, Florida. The Spiral Hurricane door has been designed to comply with the High Velocity Hurricane Zone of the Florida Building code.

The “Hilti Kwik Bolt II Mechanical Expansion anchor for Concrete and Masonry Elements” shall be supplied by Rytec Doors and approved by the Building Code Compliance Office in Miami, Florida. If there are any questions about the products in use, please contact:

Rytec Corporation  
One Cedar Parkway  
Jackson, WI 53037  
Phone: 262-677-9046  
Toll-Free: 888-GO-RYTEC (888-467-9832)  
Fax: 262-677-2058

Or  
Building Code Compliance Office  
Metro-Dade Flagler Building  
140 West Flagler Street, Suite 1603  
Miami, Florida 33130  
Phone: 305-375-2902  
Fax: 305-372-6339

# NOTICE OF ACCEPTANCE

## NOTICE OF ACCEPTANCE



DEPARTMENT OF REGULATORY AND ECONOMIC RESOURCES (RER)  
BOARD AND CODE ADMINISTRATION DIVISION  
**NOTICE OF ACCEPTANCE (NOA)**

MIAMI-DADE COUNTY  
PRODUCT CONTROL SECTION  
11805 SW 26 Street, Room 208  
Miami, Florida 33175-2474  
T (786) 315-2590 F (786) 315-2599  
[www.miamidade.gov/economy](http://www.miamidade.gov/economy)

**Rytec Corporation**  
**One Cedar Parkway**  
**Jackson, WI 53037**

### SCOPE:

This NOA is being issued under the applicable rules and regulations governing the use of construction materials. The documentation submitted has been reviewed and accepted by Miami-Dade County RER-Product Control Section to be used in Miami Dade County and other areas where allowed by the Authority Having Jurisdiction (AHJ).

This NOA shall not be valid after the expiration date stated below. The Miami-Dade County Product Control Section (In Miami Dade County) and/or the AHJ (in areas other than Miami Dade County) reserve the right to have this product or material tested for quality assurance purposes. If this product or material fails to perform in the accepted manner, the manufacturer will incur the expense of such testing and the AHJ may immediately revoke, modify, or suspend the use of such product or material within their jurisdiction. RER reserves the right to revoke this acceptance, if it is determined by Miami-Dade County Product Control Section that this product or material fails to meet the requirements of the applicable building code.

This product is approved as described herein, and has been designed to comply with the Florida Building Code, including the High Velocity Hurricane Zone.

### DESCRIPTION: Model Spiral HZ Aluminum Roll-up Door up to 16'-0" Wide

**APPROVAL DOCUMENT:** Drawing No. **9B963-R5**, titled "Spiral Rollup Door, Model Spiral HZ", Sheets 1 through 4 of 4, dated 10/02/2006, with revision dated 07/27/2012, prepared by HR Engineering, Inc, signed and sealed by Allen N. Reeves, P.E., bearing the Miami-Dade County Product Control renewal stamp with the Notice of Acceptance number and expiration date by the Miami-Dade County Product Control Section.

### MISSILE IMPACT RATING: Large and Small Missile Impact Resistant

**LABELING:** A permanent label with the manufacturer's name or logo, city, state, model/series number, the positive and negative design pressure rating, indicate impact rated if applicable, installation instruction drawing reference number, approval number (NOA), the applicable test standards, and the statement reading 'Miami-Dade County Product Control Approved' is to be located on the door's side track, bottom angle, or inner surface of a panel.

**RENEWAL** of this NOA shall be considered after a renewal application has been filed and there has been no change in the applicable building code negatively affecting the performance of this product.

**TERMINATION** of this NOA will occur after the expiration date or if there has been a revision or change in the materials, use, and/or manufacture of the product or process. Misuse of this NOA as an endorsement of any product, for sales, advertising or any other purposes shall automatically terminate this NOA. Failure to comply with any section of this NOA shall be cause for termination and removal of NOA.

**ADVERTISEMENT:** The NOA number preceded by the words Miami-Dade County, Florida, and followed by the expiration date may be displayed in advertising literature. If any portion of the NOA is displayed, then it shall be done in its entirety.

**INSPECTION:** A copy of this entire NOA shall be provided to the user by the manufacturer or its distributors and shall be available for inspection at the job site at the request of the Building Official.

This NOA renews NOA # **10-0913.03** and consists of this page 1 and evidence page E-1, as well as approval document mentioned above.

The submitted documentation was reviewed by **Carlos M. Utrera, P.E.**



*[Signature]*  
11/27/2012

NOA No. 12-0917.05  
Expiration Date: November 8, 2017  
Approval Date: December 6, 2012  
Page 1

Rytec Corporation

NOTICE OF ACCEPTANCE: EVIDENCE SUBMITTED

**A. DRAWINGS**

- 1. Drawing No. **9B963-R5**, titled "Spiral Rollup Door, Model Spiral HZ", Sheets 1 through 4 of 4, dated 10/02/2006, with revision dated 07/27/2012, prepared by HR Engineering, Inc, signed and sealed by Allen N. Reeves, P.E.

**B. TESTS**

- 1. Test report on Forced Entry Resistance Test per FBC, TAS 202-94 of a Model SST-S Roll up Door, prepared by Architectural Testing, Inc., Test Report No. **C1821.01-602-18**, dated 09/04/2012, signed and sealed by Shawn G. Collins, P.E.

*"Submitted under NOA # 06-1017.07"*

- 2. Test report on Large Missile Impact Test per FBC, TAS 201-94, Cyclic Wind Pressure Test per FBC, TAS 203-94 and Uniform Static Air Pressure Test per FBC, TAS 202-94 of Series/ Model Spiral-HZ overhead doors, prepared by ETC Laboratories, Test Report No. **ETC-05-844-16366.0**, dated 04/17/2006, signed and sealed by Joseph Labora Doldan, P.E.
- 3. Test report on Smoke Density per ASTM D2843, Rate of Burning per ASTM D 635 and Self Ignition per ASTM D 1929 of door plastic materials, prepared by ETC Laboratories, Test Report No. **ETC-06-844-17497.1**, dated 05/09/2006, signed and sealed by Joseph Labora Doldan, P.E.
- 4. Test report on Tension per ASTM E8, of door aluminum skin, prepared by ETC Laboratories, Test Report No. **ETC-06-844-17585.0**, dated 05/08/2006, signed and sealed by Joseph Labora Doldan, P.E.

**C. CALCULATIONS "Submitted under NOA # 08-1024.03"**

- 1. Calculations for Roll-up Door, Spiral SST-HZ, prepared HR Engineering, Inc, dated 10/31/2008, sheets 1 through 5, signed and sealed by Allen N. Reeves, P.E.

**D. QUALITY ASSURANCE**

- 1. Miami-Dade Department of Regulatory and Economic Resources (RER)

**E. MATERIAL CERTIFICATIONS**

- 1. Notice of Acceptance No. **11-0926.07**, issued to Dyplast Products LLC, for their Expanded Polystyrene Block Type Insulation, approved on 11/10/2011 and expiring on 01/11/2017.

**F. STATEMENTS**

- 1. Statement letter of code conformance to 2010 FBC issued by HR Engineering, Inc., dated 07/30/2012, signed and sealed by Allen N. Reeves, P.E.
- 2. Statement letter of no financial interest issued by HR Engineering, Inc., dated 07/27/2012, signed and sealed by Allen N. Reeves, P.E.

---

Carlos M. Utrera, P.E.  
 Product Control Examiner  
 NOA No. 12-0917.05  
 Expiration Date: November 8, 2017  
 Approval Date: December 6, 2012

# DOOR DIMENSIONS

# DOOR DIMENSIONS

**GENERAL NOTES**

- 1) THE RPTC SPIRAL DOOR SHOWN ON THIS PRODUCT APPROVAL DOCUMENT HAS BEEN DESIGNED IN ACCORDANCE WITH THE FLORIDA BUILDING CODE 2010. REQUIRED DESIGN WIND LOADS SHALL BE DETERMINED AS PER SECTION 1620 OF THE FBC, AND IN ACCORDANCE WITH ASCE 7-10 STANDARDS.
- 2) THE SPIRAL DOOR'S ASSEMBLY FOR IMPACT AND FORTIFED RESISTANCE HAS BEEN VERIFIED IN ACCORDANCE WITH SECTION 1626 OF THE FBC PER PROTOCOLS MS-2011, TAS-202, & TMS-203 STANDARDS.
- 3) MAXIMUM DESIGN PRESSURE ARE +50.0, -50.0 PSF.
- 4) PANEL SLATS TO BE EXTRUDED ALUMINUM ALMAGSIO 5 F-22 (6063-T6), 0.07 NOMINAL WALL THICKNESS, CLEAR ANODIZED WITH A MINIMUM YIELD STRENGTH 28KSI.
- 5) SIDE COLUMNS TO BE 11 GAGE GALVANIZED STEEL ASTM A-446 WITH A GALVANIZED COATING OF 090.
- 6) EXPANDED POLYSTYRENE FOAM, MANUFACTURED BY MAM-DADE APPROVED DYNAPLAST PRODUCTS.
- 7) CONCRETE ANCHORS TO BE 1/2" DIAMETER X 4'-1/2" LONG RED HEAD TWIN TRIBOLT WEDGE OF 1/2" HX 1/2" HX 1/2" HX EXPANSION ANCHORS, AND SHALL BE INSTALLED FOLLOWING ALL OF THE RECOMMENDATIONS AND SPECIFICATIONS OF THE ANCHOR MANUFACTURER. ANCHORS TO BE INSTALLED IN MINIMUM 400PSI CONCRETE.
- 8) IT SHALL BE THE RESPONSIBILITY OF THE CONTRACTOR TO VERIFY THAT THE EXISTING STRUCTURE IS DESIGNED TO SUPPORT V<sub>w</sub> AND V<sub>w</sub> FORCES AT BOTH JAMBS. MAX W<sub>w</sub>=1650LB/FT AND MAX V<sub>w</sub> = 400LB/FT
- 9) FOR DOOR HEIGHTS OTHER THEN 8'-0", CONCRETE ANCHOR SPACING TO BE A MAXIMUM OF 7'-1/2", BEGINNING AT 3" FROM SILL AND HEAD.
- 10) ALL DIMENSIONS ON DRAWING WITHOUT INDICATORS ARE IN INCHES.

**MANUFACTURER:**  
 RPTC CORPORATION  
 ONE CEDAR PARKWAY  
 JACKSON, MI 49307  
 PH:262-677-8066  
 FX:262-677-2058  
 www.rptcedors.com

**Product:**  
 SPIRAL ROLLUP DOOR  
 MODEL: SPIRAL HZ

**Engineering:**  
 HR Engineering, Inc.  
 1541 East Market St.  
 YORK, PA 17403  
 PH:717-846-3747  
 FX:717-846-0355  
*Allen N. Reeves*  
 Allen N. Reeves, P.E.  
 Structural Engineer  
 Florida License #19354

**Professional Engineer Seal:**  
 ALLEN N. REEVES  
 No. 19354  
 STATE OF FLORIDA  
 PROFESSIONAL ENGINEER

**Drawn By:** DAS  
**Drawn Date:** 10/2/2006  
**Scale:** Not to scale  
**Revised:** 7/27/2012

**PRODUCT REVIEWED**  
 as complying with the Florida Building Code  
 Acceptance No. 12-0912 AS  
 Engineer Date 11/08/2017  
 By *[Signature]*  
 Miami Dade Product Council

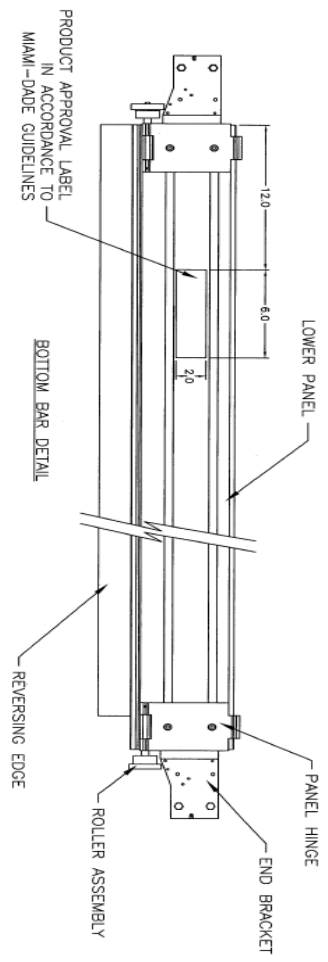
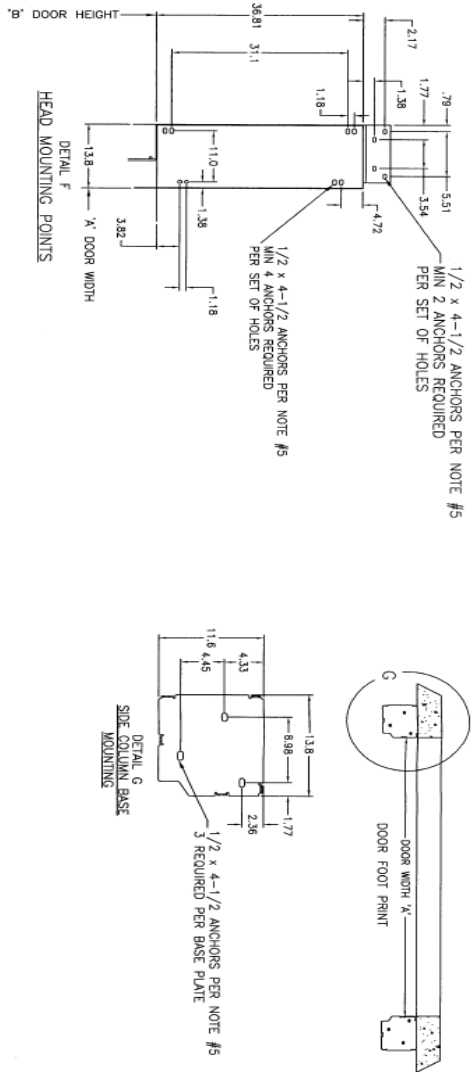
REV	DESCRIPTION	DATE	BY
6	MODIFIED PER ASCE 7-10 REQUIREMENTS.	7/27/12	RS
5	ASCE 7-05 WAS ASCE 7-98	7/29/10	DAS
4	FBC WAS 2004. CONCRETE WAS 5000PSI	11/24/08	DAS
3	ADDED SHEETS 3&4 FOR SMA-HZ	10/1/08	DAS
REV	DESCRIPTION	DATE	BY

Sheet  
1 of 4

Drawing Number  
9B963-R5



# DOOR DIMENSIONS



ITEM NO.	DESCRIPTION	QTY	MATERIAL
1	SIDE COLUMN, LH	1	GALVANIZED STEEL, ASTM A-446
2	SIDE COLUMN, RH	1	GALVANIZED STEEL, ASTM A-446
3	STANDARD PANEL SLAT	AS REQ.	ALUMINIUM, 6063-T6
4	LOWER PANEL SLAT	1	ALUMINIUM, 6063-T6
5	UPPER PANEL SLAT	1	ALUMINIUM, 6063-T6
6	GUIDE TRACK	2	ALUMINIUM, 6063-T6
7	ROLLER	AS REQ.	UHMW-PE (2) 8900ZZ ROLLER BEARINGS
8	GUIDE ROLLER	4	NYLON
9	WEATHERSEAL	4	TFE
10	REVERSING EDGE	1	EPDM

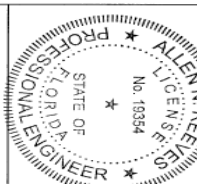
DESIGN PRESSURE RATING	IMPACT RATING
+50 PSF, -50 PSF	LARGE AND SMALL MISSILE IMPACT RESISTANT

Manufacturer:  
**RYTEC CORPORATION**  
 ONE CEDAR PARKWAY  
 JACKSON, WI 53037  
 PH:262-677-9046  
 FX:262-677-2058  
 www.rytecdoors.com

Product:  
 SPIRAL ROLLUP DOOR  
 MODEL: SPIRAL HZ

Engineering:  
 HR Engineering, Inc.  
 1541 East Market St.  
 YORK, PA 17403  
 PH:717-846-3747  
 FX:717-846-0355

*Allen N. Reeves*  
 Allen N. Reeves, P.E.  
 Structural Engineer  
 Florida License #19354



Drawn By: DAS  
 Drawn Date: 10/2/06  
 Scale: Not to scale  
 Revised: 7/27/2012

PRODUCT REBUILT  
 in compliance with the Florida  
 Building Code **2007**  
 Approved by **10/2/2012**  
 By *[Signature]*  
 Miami-Dade Product Control

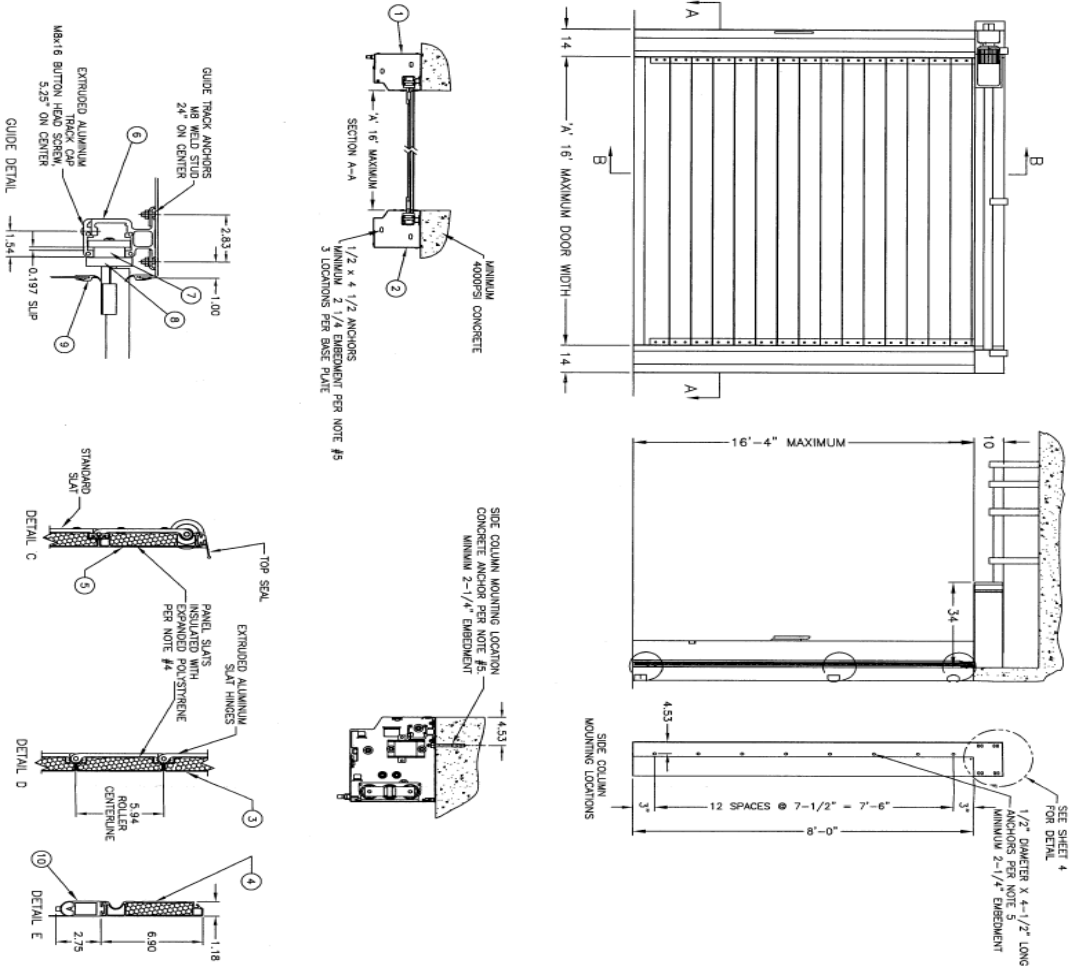
Drawing Number  
**9B963-R5**

Sheet  
 2 of 4

# DOOR DIMENSIONS

**GENERAL NOTES**

- 1) THE RYTEC SPIRAL DOOR SHOWN ON THIS PRODUCT APPROVAL DOCUMENT HAS BEEN DESIGNED IN ACCORDANCE WITH THE FLORIDA BUILDING CODE 2010. REQUIRED DESIGN WIND LOADS SHALL BE DETERMINED AS PER SECTION 1620 OF THE FBC AND IN ACCORDANCE WITH ASCE 7-10 STANDARD.
- THE SPIRAL DOOR'S ADEQUACY FOR IMPACT AND FATIGUE RESISTANCE HAS BEEN VERIFIED IN ACCORDANCE WITH SECTION 1626 OF THE FBC PER PROTOCOLS TAS-201, TAS-202, & TAS-203 STANDARDS.
- MAXIMUM DESIGN PRESSURE ARE +90.0, -50.0 PSF.
- 2) PANEL SLATS TO BE EXTRUDED ALUMINUM ALMAGS03 F-22 (6063-T5), 0.07 NOMINAL WALL THICKNESS, CLEAR ANNOXIDIZED WITH A MINIMUM TELD STRENGTH 29KSI.
- 3) SIDE COLUMNS TO BE 11 GAUGE GALVANIZED STEEL ASTM A-446 WITH A GALVANIZED COATING OF 990.
- 4) OPTIONAL PANEL SLAT INSULATION TO BE EPS - EXPANDED POLYSTYRENE FOAM, MANUFACTURED BY MAH-DADE APPROVED DYNAPLAST PRODUCTS.
- 5) CONCRETE ANCHORS TO BE 1/2" DIAMETER x 4-1/2" LONG RED HEAD JMW TRIBOLT WEDGE OR HILTI KWIK BOLT II EXPANSION ANCHORS, AND SHALL BE INSTALLED FOLLOWING ALL OF THE RECOMMENDATIONS AND SPECIFICATIONS OF THE ANCHOR MANUFACTURER. ANCHORS TO BE INSTALLED IN MINIMUM 4000PSI CONCRETE.
- 6) IT SHALL BE THE RESPONSIBILITY OF THE CONTRACTOR TO VERIFY THAT THE EXISTING STRUCTURE IS DESIGNED TO SUPPORT Vx AND Vy FORCES AT BOTH JAMBS. MAX W=16500LB/FT AND MAX Vy = 4000LB/FT
- 7) FOR DOOR HEIGHTS OTHER THEN 8'-0", CONCRETE ANCHOR SPACING TO BE A MAXIMUM OF 7'-1/2", BEGINNING AT 3" FROM SILL AND HEAD.
- 8) ALL DIMENSIONS ON DRAWING WITHOUT INDICATORS ARE IN INCHES.



Manufacturer:

**RYTEC CORPORATION**  
 ONE CEDAR PARKWAY  
 JACKSON, WI 53037  
 PH:262-677-9046  
 FX:262-677-2055  
 WWW.RYTECDOORS.COM

Product:  
 SPIRAL ROLLUP DOOR  
 MODEL: SPIRAL\_HZ

Engineering:

**HR Engineering, Inc.**  
 1541 East Market St.  
 YORK, PA 17403  
 PH:717-846-3147  
 FX:717-846-4353  
*Darryl Reeves*  
 Darryl Reeves, P.E.  
 Structural Engineer  
 Florida License #193354

**ALLEN N. REEVES**  
 No. 19354  
 STATE OF FLORIDA  
 PROFESSIONAL ENGINEER

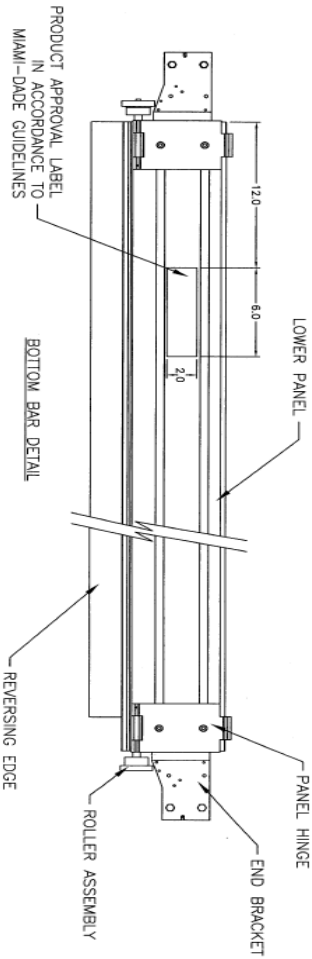
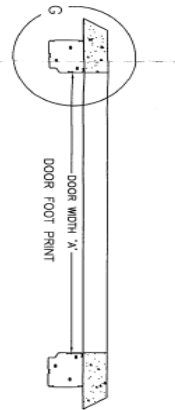
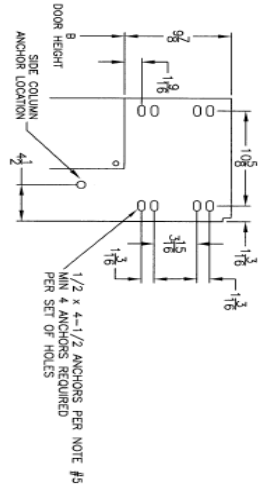
Drawn By: DAS  
 Drawn Date: 10/22/06  
 Scale: Not to scale  
 Revised: 7/27/2012

**PRODUCT REVIEWED**  
 in compliance with the Florida  
 Building Code  
 Approval No: *12-9972-05*  
 Expiration Date: *11/08/2017*  
 By: *[Signature]*  
 Member of the Florida Council

Drawing Number  
**9B963-R5**

Sheet  
 3 of 4

# DOOR DIMENSIONS



BILL OF MATERIAL			
ITEM NO.	DESCRIPTION	QTY	MATERIAL
1	SIDE COLUMN, LH	1	GALVANIZED STEEL, ASTM A-446
2	SIDE COLUMN, RH	1	GALVANIZED STEEL, ASTM A-446
3	STANDARD PANEL SLAT	AS REQ.	ALUMINUM, 6063-T6
4	LOWER PANEL SLAT	1	ALUMINUM, 6063-T6
5	UPPER PANEL SLAT	1	ALUMINUM, 6063-T6
6	GUIDE TRACK	2	ALUMINUM, 6063-T6
7	ROLLER	AS REQ.	UHMW-PE (2) 6900ZZ, RADIAL BEARINGS
8	GUIDE ROLLER	4	NYLON
9	WEATHERSEAL	4	EPDM
10	REVERSING EDGE	1	EPDM

DESIGN PRESSURE RATING	IMPACT RATING
+50 PSF, -50 PSF	LARGE AND SMALL MISSILE IMPACT RESISTANT

Manufacturer:

**RYTEC CORPORATION**

ONE CEDAR PARKWAY  
JACKSON, MI 48307  
PH:262-977-8046  
FX:262-977-2098  
www.rytedoors.com

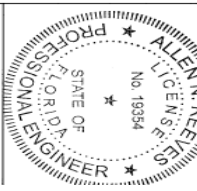
Product:

SPIRAL ROLLUP DOOR  
MODEL: SPIRAL HZ

Engineering:

HR Engineering, Inc.

1541 East Market St.  
YORK, PA 17403  
PH:717-846-3147  
FX:717-846-0353  
C. H. Reeves & Co. Inc.  
Allen N. Reeves, P.E.  
Structural Engineer  
Florida License #19354



Drawn By: DAS  
Drawn Date: 10/2/06  
Scale: Not to scale  
Revised: 7/27/2012

**PRODUCT RETURNED**  
FOR REPAIR WITH THE FLORIDA  
BUILDING CODE  
Acceptance No. **12-0917-05**  
Expiration Date **11/01/2017**  
By: *[Signature]*  
Miami Code Product Control

Drawing Number  
**9B963-R5**

Sheet  
4 Of 4

## INTRODUCTION

### INTRODUCTION

The information contained in this manual will allow you to install your Rytec Spiral<sup>®</sup> LH-HZ Door in a manner which will ensure maximum life and trouble-free operation.

Any unauthorized changes in procedure, or failure to follow the steps as outlined in this manual, will automatically void the warranty. Any changes in the working parts, assemblies, or specifications as written that are not authorized by Rytec Corporation will also cancel the warranty. The responsibility for the successful operation and performance of this door lies with the owner of the door.

**DO NOT OPERATE OR PERFORM MAINTENANCE ON THIS DOOR UNTIL YOU READ AND UNDERSTAND THE INSTRUCTIONS CONTAINED IN THIS MANUAL.**

If you have any questions contact your Rytec representative or call the Rytec Technical Support Department at 800-628-1909. Always refer to the serial number of the door when calling the representative or Technical Support.

The wiring connections and schematics in this manual are for general information purposes only. A wiring schematic is provided with each individual door specifically covering the control panel and electrical components of that door. That schematic was shipped inside the cover of the System 4 control panel.

#### DOOR SERIAL NUMBER(S)

To obtain your **DOOR SERIAL NUMBER**, there are three universal locations that this information can be attained. These are on the left side column (approximately eye level), on the drive motor and the inside door of the System 4 control panel. (See Figure 1.)

**IMPORTANT:** *When installing multiple doors of the same model but in different size, verify the serial number in the control panel with the left side column.*

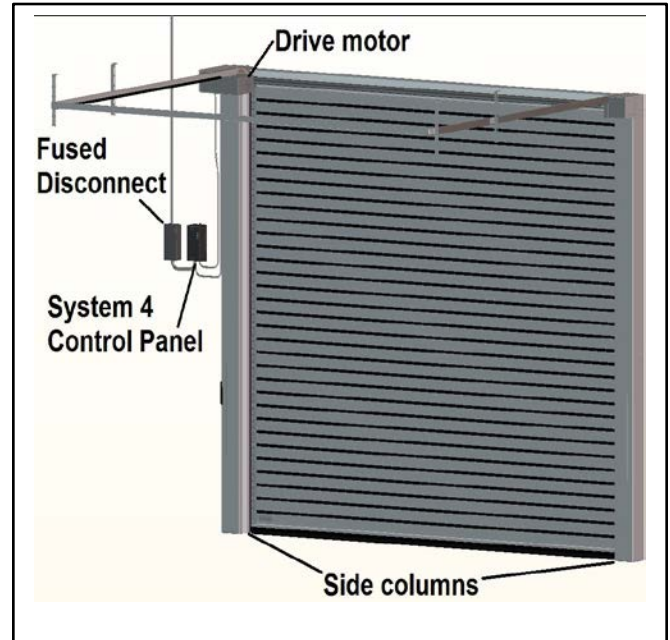


Figure 1

### HOW TO USE MANUAL

Throughout this manual, the following key words are used to alert the reader of potentially hazardous situations, or situations where additional information to successfully perform the procedure is presented:



**WARNING** is used to indicate the potential for personal injury, if the procedure is not performed as described.



**CAUTION** is used to indicate the potential for damage to the product or property damage, if the procedure is not followed as described.

**IMPORTANT:** **IMPORTANT** is used to relay information **CRITICAL** to the successful completion of the procedure.

**NOTE:** **NOTE** is used to provide additional information to aid in the performance of the procedure or operation of the door, but not necessarily safety related.

## INSTALLATION

### MATERIAL, TOOLS, AND EQUIPMENT

1. Rytec provided approved anchors (1/2-in. diameter)  
(See "ANCHORING METHODS" on page 10.)
2. Assorted shim stock.
3. Double-sided tape.
4. Package of oversize plastic cable ties.
5. Mounting hardware for field-installed photo eye brackets.
6. Carpenter's or spirit level (4-ft. minimum length).
7. Carpenter's square.
8. Hammer drill.
9. Masonry drill bit (for 1/2-in. diameter anchors).
10. Three or four bar clamps (18-in. long).
11. Hammer or mallet, and block of wood.
12. Crowbar or pry bar.
13. Assorted hand tools (pliers, tape measure, etc.).
14. Plumb bob with line.
15. Metric and U.S. socket and wrench sets.
16. T-30, T-40, and T-50 Torx drivers.
17. Water level, line level, or transit.
18. Two ladders (taller than height of door opening).
19. Forklift (See "Forklift Requirements" on page 9).

### ADDITIONAL REQUIREMENTS

#### Labor and Site Requirements

1. Two installers.
2. A licensed electrician is required for making all electrical connections.

*NOTE: All electrical work must be performed in accordance with local and state building codes.*

3. 100% accessibility to the door opening during the entire installation process. No traffic should be allowed to pass through the opening while the door is being installed.

#### Electrician's Responsibilities

*NOTE: See "CONTROL SYSTEM" on page 35, for complete details on the electrical work to be performed.*

1. Install fused disconnect and Rytec control panel.  
(See Figure 2 for typical installation.)
2. Install all necessary conduit tubing.

*NOTE: Separate high and low voltage conduit.*

3. Run electrical power lines to disconnect.
4. Run power lines from disconnect to control panel.
5. Run power lines from control panel to upper junction box.
6. Run power lines from control panel to door motor.
7. Run low-voltage cables from door to control panel.
8. Mount rear photo eyes.
9. Wire low-voltage safety devices and activators (if used).

#### Forklift Requirements

A forklift supplied by the customer, dealer, or installer is mandatory for the safe and proper installation. The forklift should have:

- 4,000-pound lift capacity
- minimum height ability — door height, plus 12-in.
- 48-in. wide fork
- side-shift capability (desired)

#### Floor-Loop Activator Requirements (If Used)

If a floor-loop activator shipped with your Rytec door, the following additional items are required.

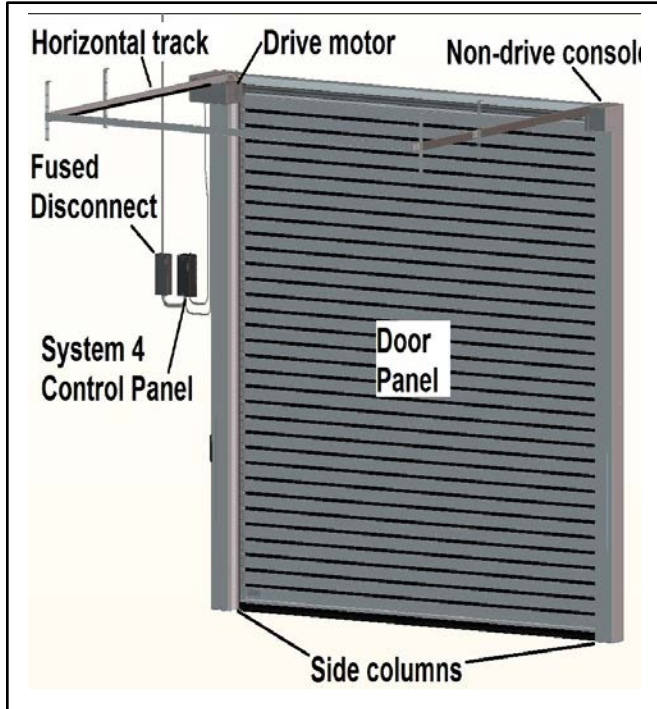
*NOTE: Complete floor-loop installation instructions, shipped with the activator.*

1. Concrete saw (with water-cooling attachment).
2. Water supply and garden hose.
3. Wet/dry shop vacuum.
4. 200–500 ft. of 16-gauge, 19-strand, type XLPE, copper, crosslink polyethylene jacket wire (or equivalent). The size of the floor loop will determine the length of wire required.
5. Bondo P606 Flexible Embedding Sealer (or equivalent) — required to fill saw cuts in floor after the activator is installed. For cold temperature applications, Bondo P610 Speed Set must be added to the P606 to ensure the sealer cures properly.

# INSTALLATION

## TYPICAL INSTALLATION

Figure 2 shows the location of the major components of your Spiral LH-HZ door. This illustration should be used as reference only and should not be used as part of the installation instructions.

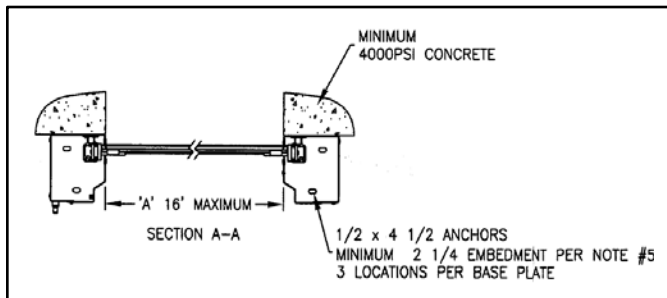


**Figure 2**

*NOTE: The above illustration shows the front side of the door. Left and right are determined when viewing the front side of the door.*

## MINIMUM CONCRETE REQUIREMENT

Minimum 4000 PSI concrete required for installation. (See Figure 3.)



**Figure 3**

## ANCHORING METHOD

The Rytec Spiral LH-HZ has been designed in accordance with the Florida building code 2010. Required design wind loads determined as per section 1620 of the FBC (Florida Building Code) and in accordance with ASCE 7- 10 standards.

The Spiral LH-HZ door's adequacy for impact and fatigue resistance has been verified in accordance with section 1626 of the FBC per protocols TAS-201, TAS-202, & TAS-203 standards.

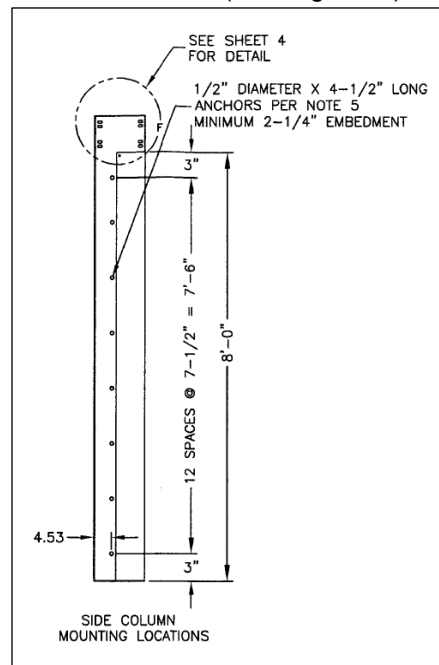
Maximum design pressures are +50.0, -50.0 PSF.

To maintain the hurricane rating the door **MUST** be installed on a concrete wall minimum 4000 PSI.

The anchor hardware has been provided by Rytec to meet the specifications of the hurricane rating. Failure to use the provided hardware and install in the specific method will void the warranty.

The anchors are 1/2" x 4 1/2" and must have a minimum embedment of 2 1/4" into the concrete. All anchor hole locations must be filled. There are 3 anchor locations in the base of the side columns.

Starting 3 inches from the floor and every 7 1/2" in the side columns, located 4.53 inches from the inside edge of the side column. (See Figure 4.)

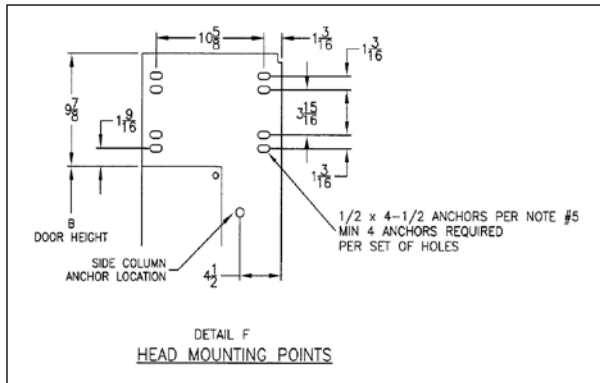


**Figure 4**

**IMPORTANT: Rytec Corporation provides the approved anchors for installation. These anchors **MUST** be use. Hilti Kwik bolt II expansion anchors 1/2" diameter x 4 1/2" long**

**DETAILS - TOP OF SIDE COLUMN**

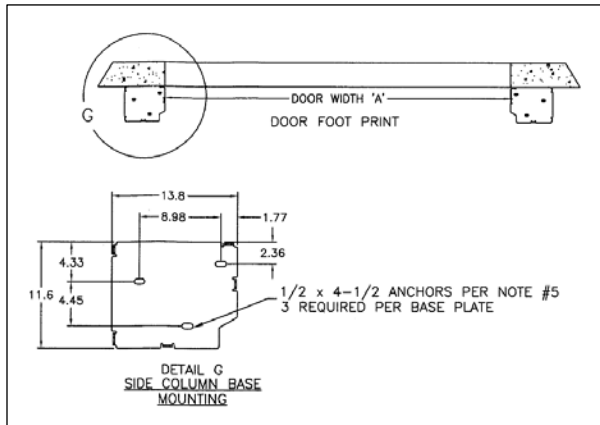
The top of the side column has a number of anchor holes. The anchor holes are located very near each other. One inside and one outside hole must be used in each location at the top of the side column. A minimum of 2 anchors at each location will be used. (See Figure 5.)



**Figure 5**

**BASE PLATE - ANCHOR LOCATIONS**

Each side column base plate has 3 anchor hole locations and all 3 MUST be used. (See Figure 6.)



**Figure 6**

**IMPORTANT: 2 1/4" Embedment required for anchor holes.**

**UNCRATING**

NOTE: Remove parts and sub-assemblies from the shipping crate in the order directed throughout this manual.

1. Remove the two side column assemblies, spring pack assemblies, and the small parts carton from the shipping crate. (See Figure 7.)



**Figure 7**



# LOCATE THE CENTERLINE OF DOOR OPENING

## LOCATE CENTERLINE OF DOOR OPENING

NOTE: Accurate measurements are critical for the proper installation and operation of your Rytec door. Verify all measurements.

1. Measure the width of the door opening. Then divide the measurement in half to locate the centerline. Mark the centerline along the floor. (See Figure 8.)

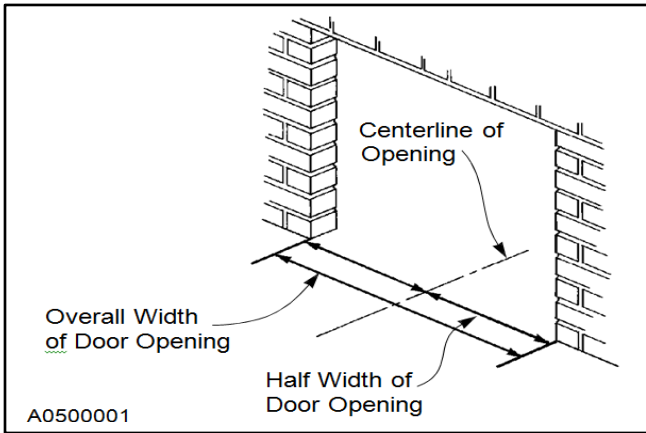


Figure 8

## LOCATING SIDE COLUMNS

1. Locate the layout drawing of the door. It should be attached to the small parts carton. This drawing identifies the production width of your door.
2. Using the centerline as a reference point, lay out and mark half of the door's production width along the floor. (See Figure 9.)

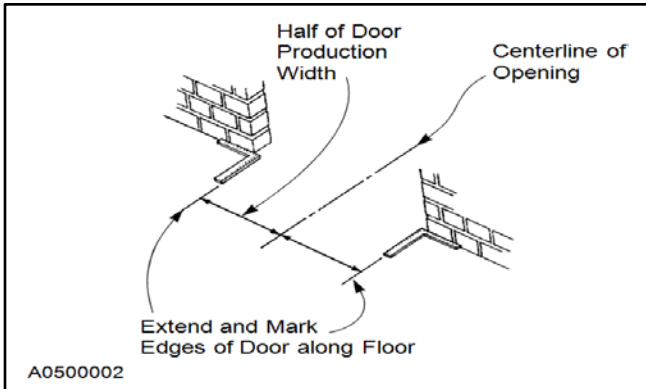


Figure 9

3. With a carpenter's square placed against the wall, mark both sides of the door along the floor. Extend the line along each edge

4. Check that the floor is level across the door opening. The floor must be level within 0.12 in. (3 mm) from side to side. If one side of the opening is higher than the other, a shim under the side column will be required.

Figure 10 and Figure 11 show two recommended methods that can be used to ensure a level side column installation.

NOTE: Contact the Rytec Technical Support Department if the floor is more than 1 in. out of level.

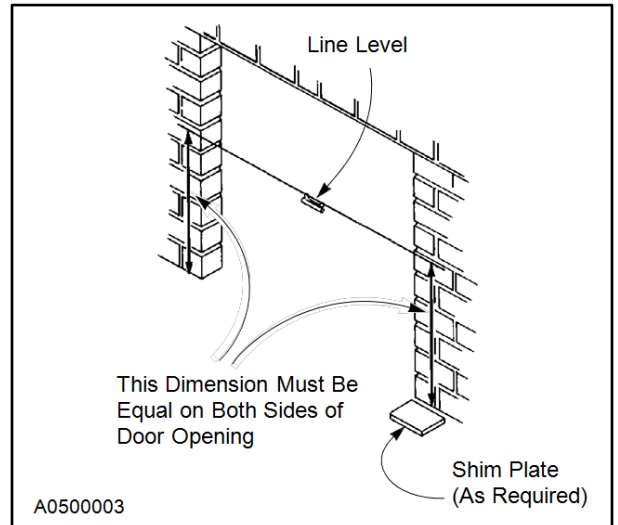


Figure 10

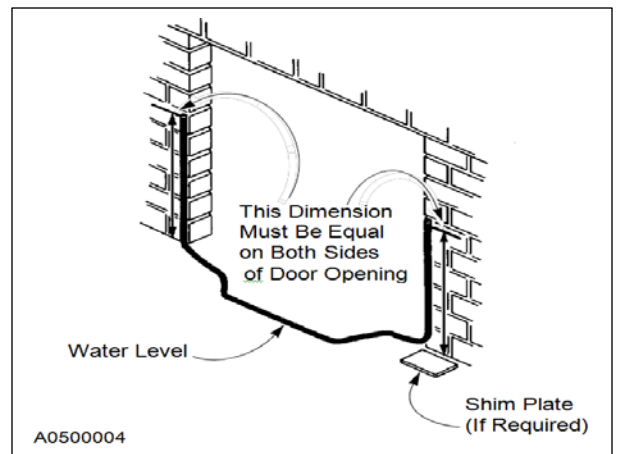
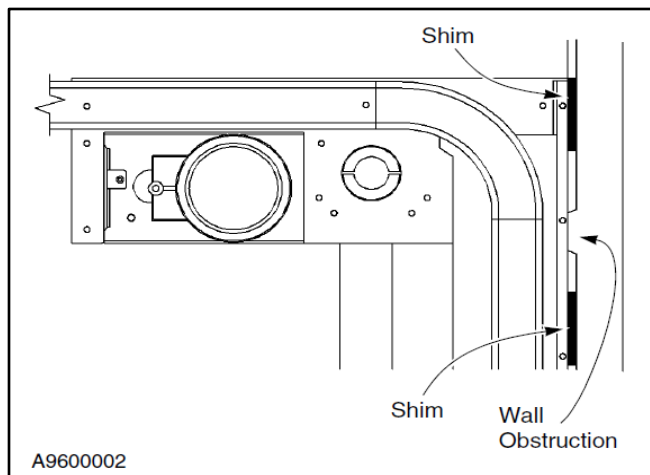


Figure 11



- Use a plumb bob or carpenter's level to check the wall for plumb in the areas where the side columns are to be mounted. Also, inspect the wall for any obstructions.

If the wall is not plumb, use shims. If you find an obstruction, remove it, or shim the column to avoid the obstruction. (See Figure 12.)

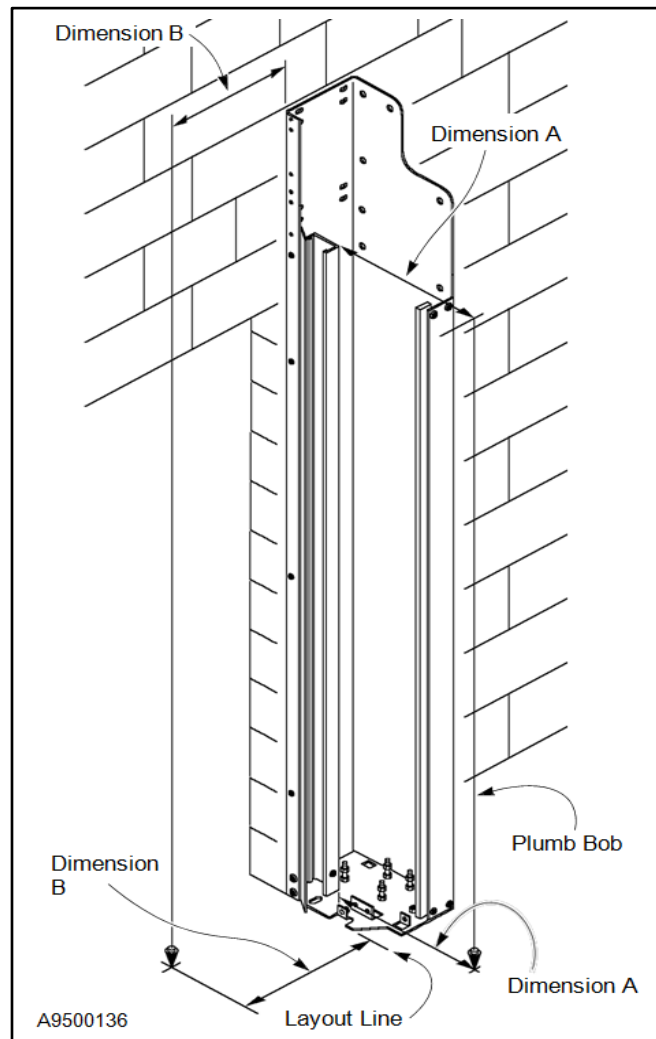


**Figure 12**

### SIDE COLUMNS

- To install the first side column, first remove and retain the screws used to secure the column cover to the side column assembly. Lift away the cover.
- Stand the side column assembly on the floor, with the back of the column firmly against the wall. (See Figure 13.)

*NOTE: Set the inside edge of the column flush with the door layout line.*



**Figure 13**

- Position the column so that it is plumb to the wall and square with the floor.

A plumb bob or carpenter's level are recommended for setting the column plumb and square. The use of bar clamps to temporarily secure the column to the wall during installation is also recommended. When required shim behind the side column if the wall is out of plumb. To hold the shims in place until the column is secured attach them to the wall or column with double-sided tape. (See Figure 14.)

### USING A PLUMB BOB

To check for plumb measure a few inches away from the face of the side column near the top (Dimension A) and drop the plumb bob. (See Figure 13.)

## SIDE COLUMNS

Mark the floor where the plumb bob touches. Compare the upper measurement to the lower measurement. Shim the column toward or away from the wall, as required, until the two measurements are equal and the column is plumb to the wall.

Also, measure a few inches away from the side of the column near the top (Dimension B) and drop the plumb bob. (See Figure 13.) Mark the floor where the plumb bob touches. Compare the upper measurement to the lower measurement. Lean the column to the left or the right until the two measurements are equal and the column is plumb with the floor (or shim plate).

### USING A CARPENTER'S LEVEL

Hold the level firmly against the face and side of the column. Make the necessary adjustments to set the side column level.

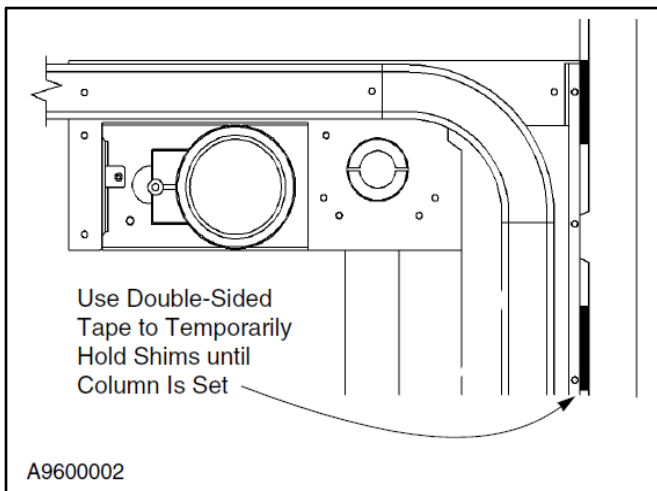


Figure 14

4. Temporarily clamp the side column to the wall once the column is properly positioned.
5. Using the predrilled anchor points in the back of the column as a reference, mark their location on the wall. (See Figure 15.)

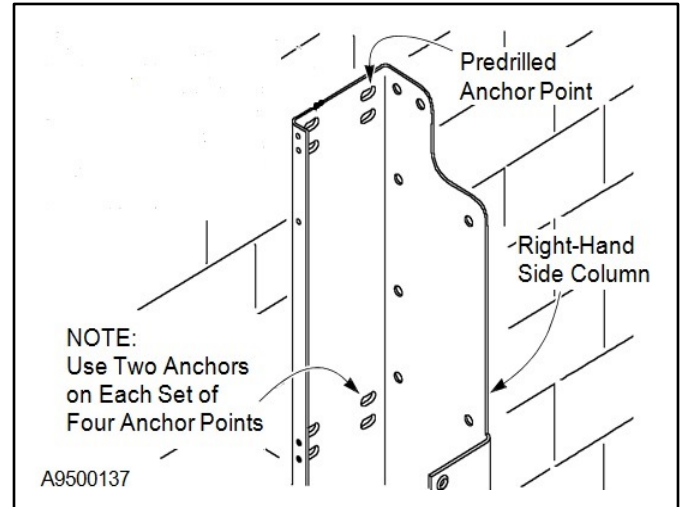


Figure 15

6. Using the predrilled anchor points in the base plate as a reference, mark their location on the floor. (See Figure 16.)

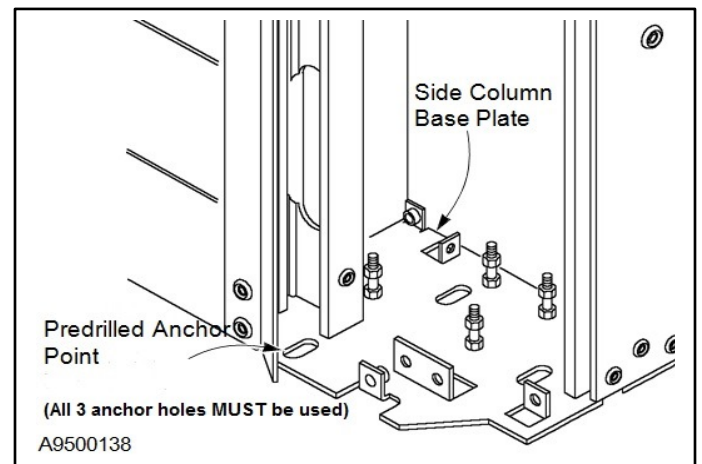


Figure 16

Unclamp and set the column aside. Drill holes into the floor and through the wall for all anchors.

## **⚠ WARNING**

**Before drilling any holes, ensure there are no electrical wires, water pipes, or gas lines, etc., buried in the floor or hidden in the wall.**

7. Reposition and re-clamp the side column to the wall. Secure the base plate to the floor with the appropriate anchors. Do not over-tighten the anchors at this time.

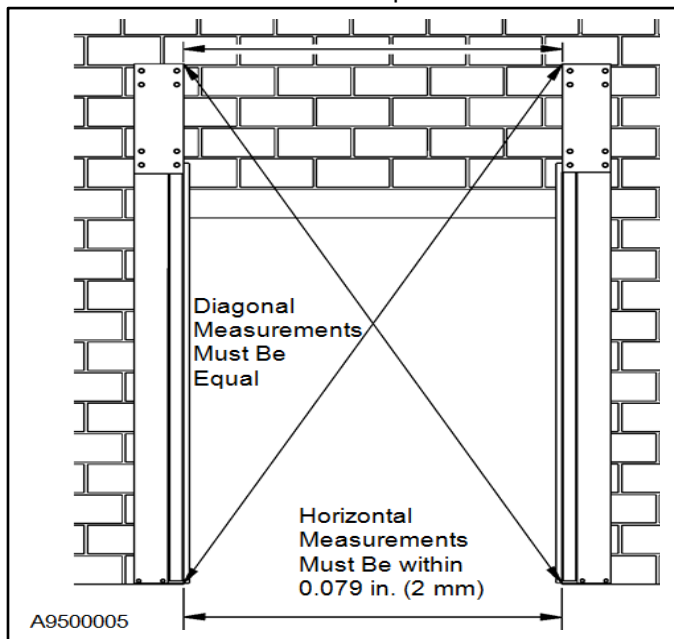
8. Anchor the side column to the wall using the provided anchors (see "ANCHORING METHOD" on page 10) and all drilled anchor points. Do not tighten the anchors at this time. They should just be snug.
9. Mount the remaining side column to the floor and wall in the same manner as outlined for the previous side column.

*NOTE: To ensure the side columns are positioned identically, take measurements for each column from similar points of reference*

10. With both columns set and snugly bolted in place, check the overall square-ness of each column. (See Figure 17.)

Compare the diagonal measurements and the upper and lower horizontal measurements across the columns. The columns are square and parallel when the diagonal measurements are equal and the horizontal measurements are equal.

If either column requires a slight repositioning (when the difference of either comparison is greater than 1/4 in.), use a block of wood and a mallet to move the column into position.



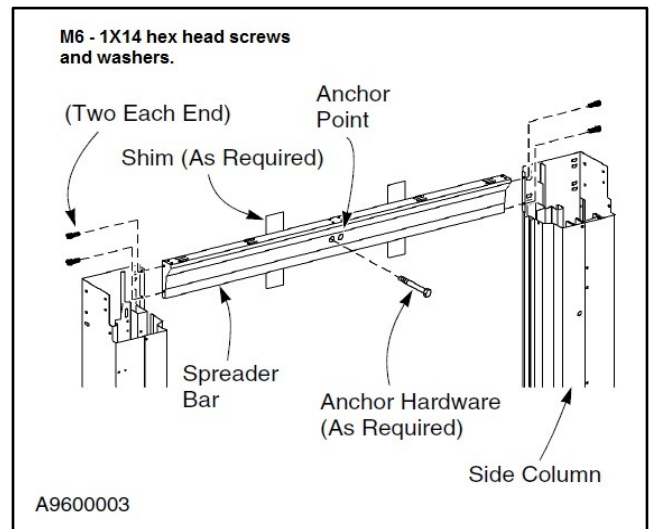
**Figure 17**

11. Double-check all measurements. Then firmly tighten all floor and wall anchors.

**REAR SPREADER**

To make it possible to install the spreader bar, and the head assembly later on, the door track running along the inside edge of each side column must first be released and slid out of the way.

1. Each section of door track is attached to the side column by a series of aluminum clips that are bolted to the back of the column. Loosen the hex nut that locks each clip in place.
2. Once each clip is loose, slide the door track to the bottom of the side column.
3. With the curved side of the spreader bar facing away from the wall, attach the ends of the spreader to the side columns. Use two M6 – 1x14 hex head screws and washers at each end. The screws are located in the small parts carton. (See Figure 18.)



**Figure 18**

4. Using the appropriate hardware, secure the spreader bar to the wall at the two anchor points in the center of the spreader. The rear spreader must be secured to the wall at all anchor points.

*NOTE: When securing the spreader to the wall, it will be necessary for you to mark the location of the wall anchors using the holes in the spreader as reference. After drilling the required holes and installing the anchors, permanently secure the spreader bar to the wall.*

*Also, if shims or spacers were installed behind the side columns, it will be necessary for you to shim behind the spreader as well.*

## CONSOLE ASSEMBLY

5. Tighten all hardware in the side columns and rear spreader. Check the alignment of the side columns and rear spreader with a level. Adjust as necessary.

### CONSOLE ASSEMBLY



**DO NOT lift the console assembly without clamping or securing it to the forklift. Failure to securely fasten the console assembly to the forklift can result in property damage and/or personal injury.**

**NOTE:** The console assembly is extremely heavy. The use of a mechanical lift is required if the ceiling height is too low to allow the use of a forklift for installing the console assembly.

1. Carefully lift and remove the console assembly from the shipping crate. (See Figure 19.)

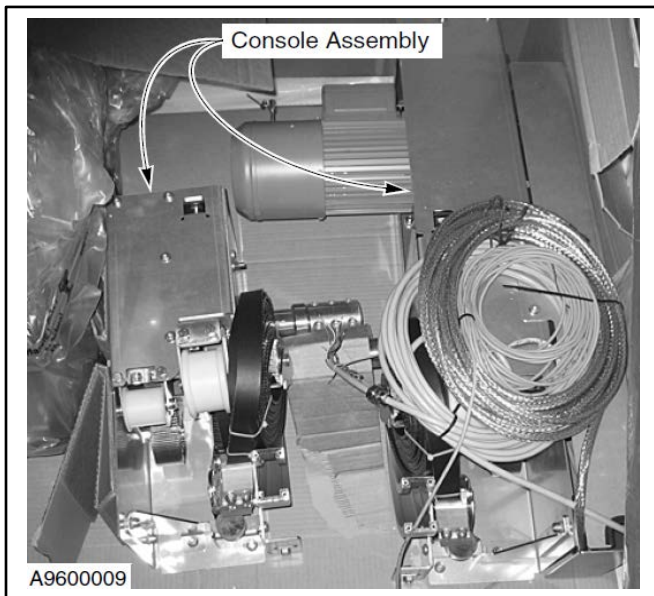


Figure 19

2. Before lifting the console assembly into position, remove all covers. Retain all fasteners. (See Figure 20.)

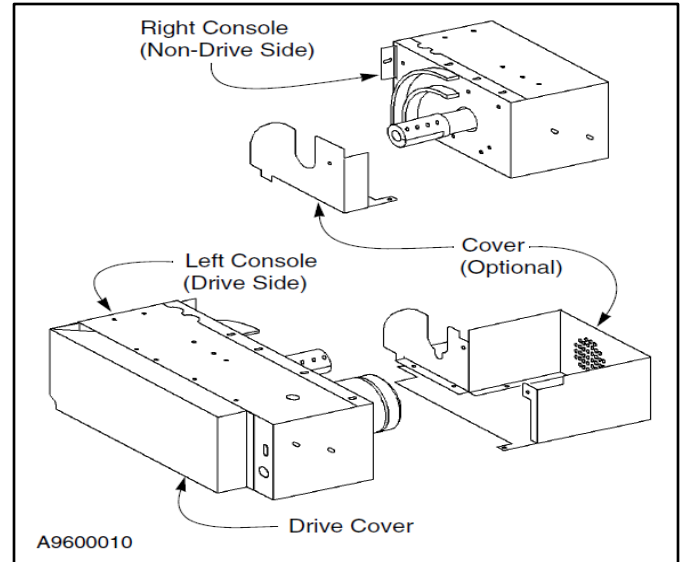


Figure 20

3. Remove cap screws on both consoles. Retain the fasteners to use for the installation of the console to the side columns. (See Figure 21 and figure 22.)

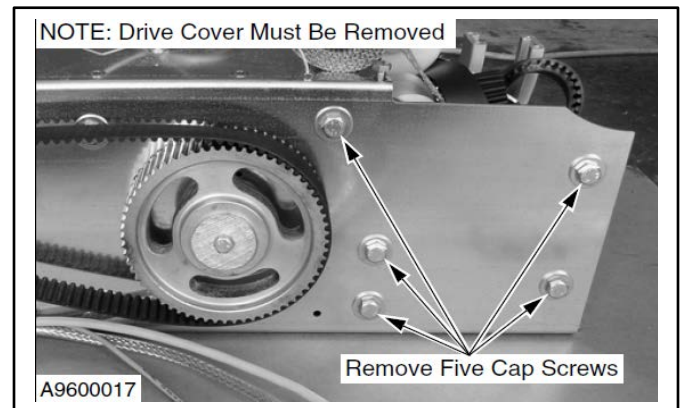


Figure 21

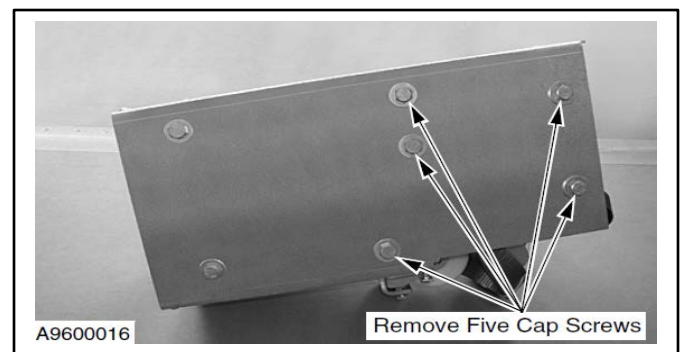
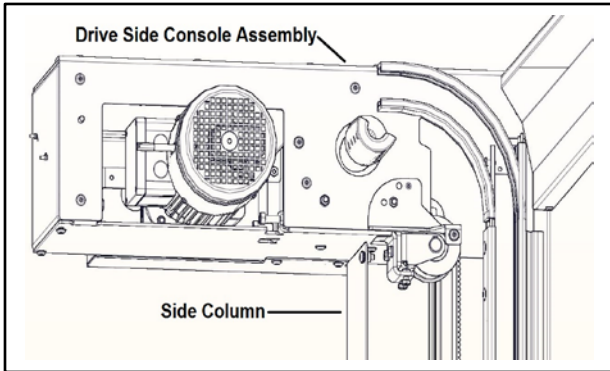


Figure 22

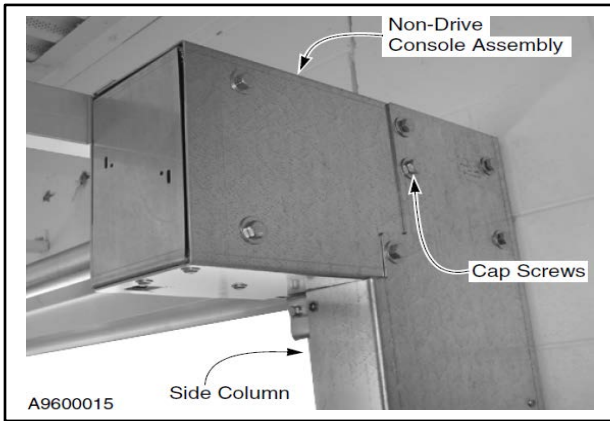


4. Raise and position the console assembly above each side column so that it is parallel to the wall and level with each side column. Align the console assembly with the side column and install the five cap screws that were removed in step 3. (See Figure 23 and figure 24.)

*NOTE: Use extreme care when lowering the console assembly into position.*

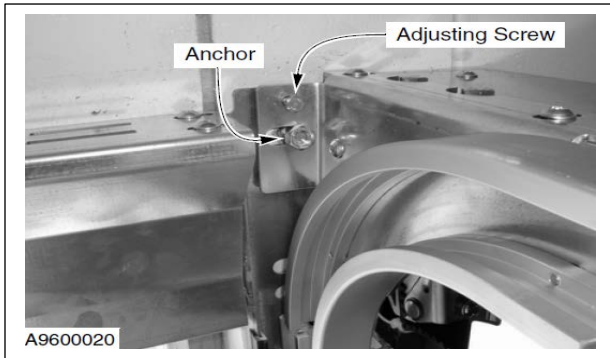


**Figure 23**



**Figure 24**

5. Secure the console assemblies to the wall with the provided anchors.

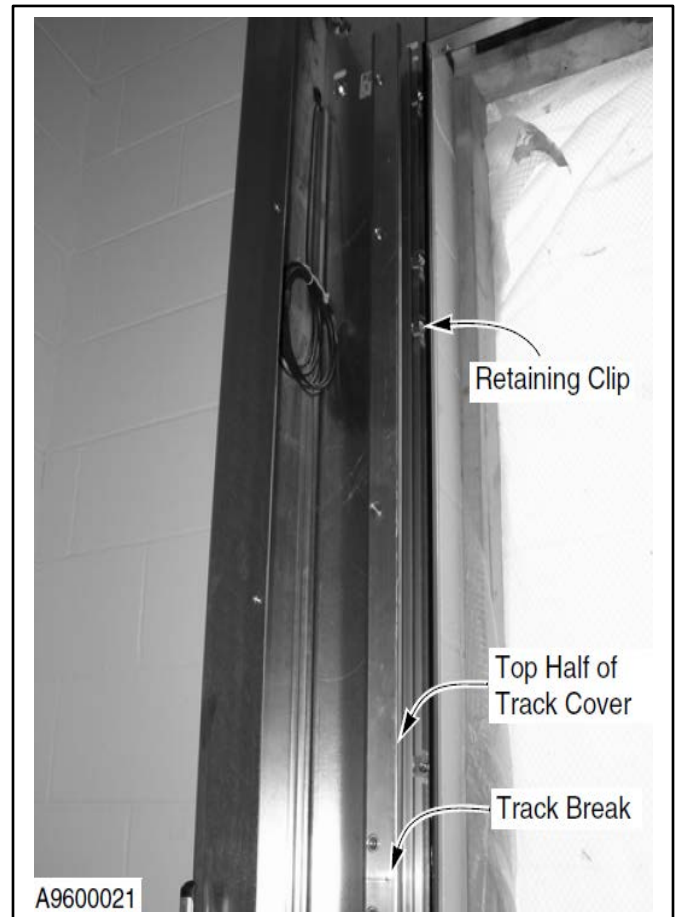


**Figure 25**

6. Remove the track cover. Loosen the hardware to the retaining clips and lower the track assembly. (See Figure 26.)

*NOTE: Depending on height of the door, the track cover may be a one or two piece unit. If it is a two piece unit, the top half of the track cover should be removed as shown in Figure 26.*

*Spacers are used to ensure a gap between the back of the column and the guide rail (track). Be sure that the spacers have not fallen to the bottom of the side column. Should they fall out of position, make sure they are spaced between mounting bolts.*

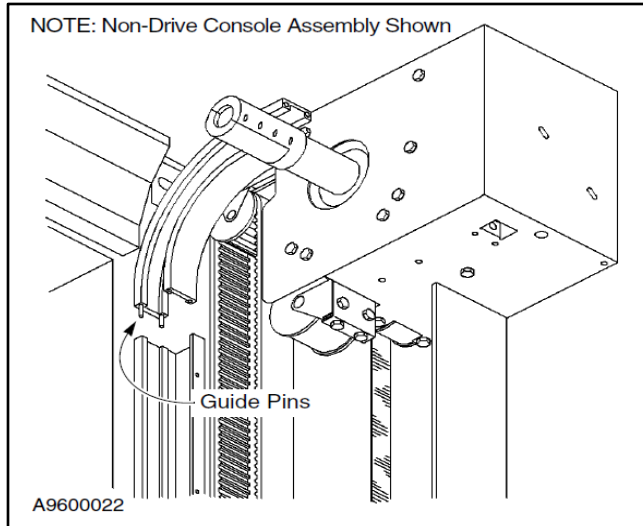


**Figure 26**

## CONNECTION SHAFT

7. Insert the two guide pins into the rear holes in the console assembly guide rails.  
(See Figure 27)

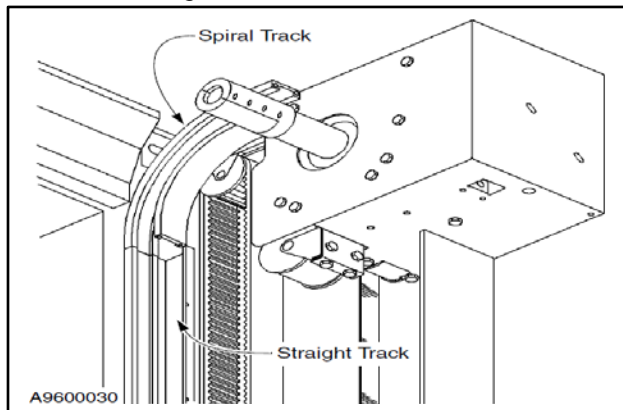
*NOTE: Lubricate the pins to ease installation*



**Figure 27**

8. Insert the two guide pins into the top half of the front track cover.
9. Slide each length of straight track up against the spiral track. To secure the track to the side column, lock the retaining clips to the track by threading the hex nut tight against the clip. (See Figure 28.)

*NOTE: Spacers are used to ensure a gap between the back of the column and the guide rail (track). Be sure that the spacers have not fallen to the bottom of the side column. Should they fall out of position, make sure they are spaced between mounting bolts.*



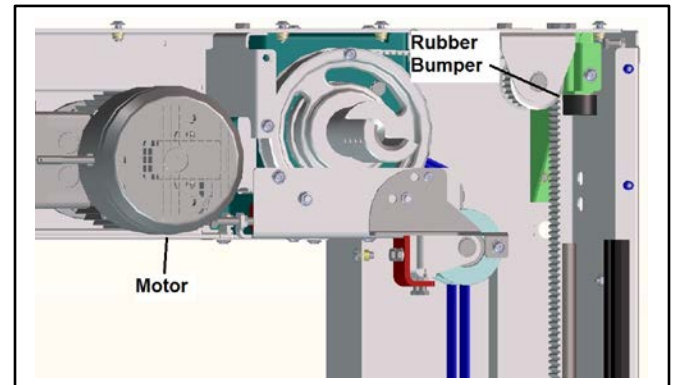
**Figure 28**

## CONNECTION SHAFT

*NOTE: Check that all side columns, rear spreader, and console assemblies are properly anchored and that hardware is tightened prior to installation.*

*The following procedure may be used with either console assembly as a starting point.*

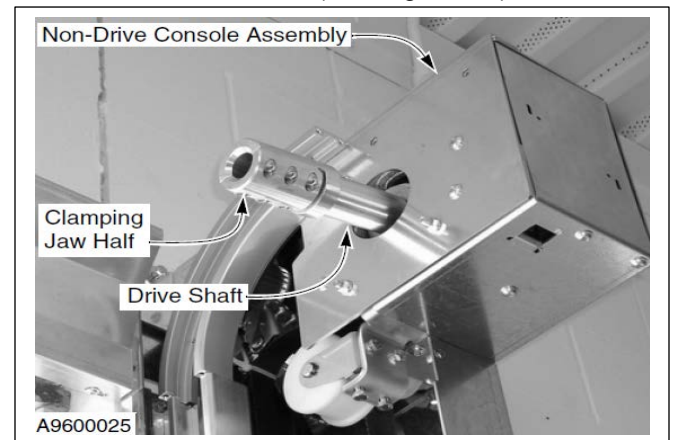
1. Turn the drive shafts of both consoles until the jaw clamps of the serrated belts arrive at the upper rubber bumper. (See Figure 29.) The blue nylon strap has pre-wraps wound onto the drive shafts. The blue straps **MUST** have pre-wraps and be equal in length on both sides after cutting the cable tie free. The clamping jaws for the drive shaft should also be in the same position when aligned properly. (See Figure 37. The sample packing sheet shows that three wraps are required for that size of door.)



**Figure 29**

*NOTE: Covers removed for clarity.*

2. Remove the hardware and the clamping jaw half from the drive shaft. (See Figure 30.)



**Figure 30**

- Loosen the hardware on the opposite end of the drive shaft but do not remove the clamping jaw half, and insert the end of the connection shaft. (See Figure 31.)

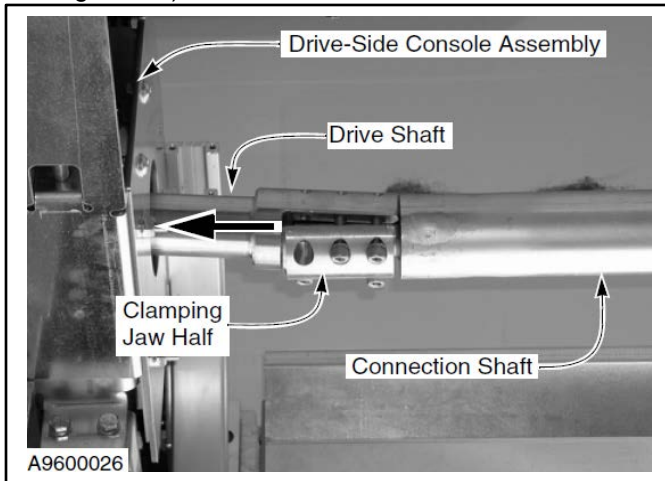


Figure 31

- Insert the opposite end of the connection shaft into the drive shaft and install the clamping jaw half. Provide an equal gap on both ends between the drive shaft and connection shaft. (See Figure 32.)

*NOTE: For proper belt alignment, the drive shafts should be pushed out as far as possible away from the connecting shaft.*

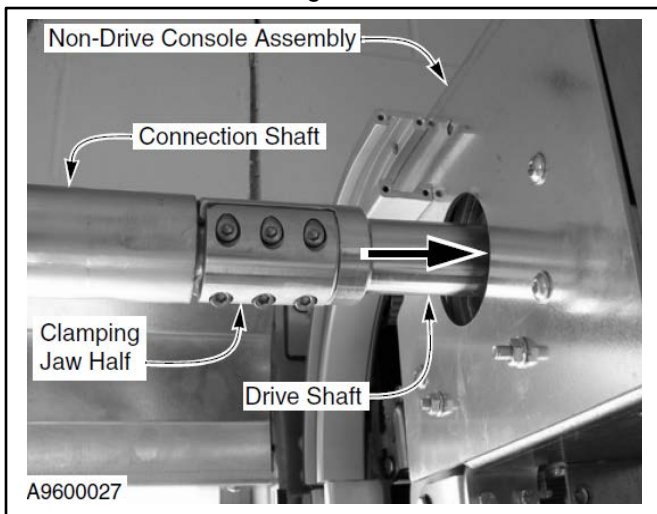


Figure 32

- On the opposite end. Verify the gap between the drive shaft and connection shaft. Tighten the clamping jaw halves.
- Insert the serrated belt and blue nylon strap into their respective pulleys.

## MOTOR DRIVE BELT

The motor drive belt must be tensioned. Final tensioning must be carried out with the door closed. To do this, measure the low tension side. With a testing force of 22.5 lbf, the deflection of the belt should be 0.393 in.

*NOTE: If the drive belt still jumps despite being tightened as above, the depth of deflection can be reduced by 0.078 in.*

*If the belt is tensioned too much, the bearing of the connecting shaft or the connection shaft itself can be affected.*

## SPRING PACK AND DRIVE BELT

The spring pack mechanism consists of spring assemblies and belts. It balances out the weight of the door panel assembly. This mechanism also assists the drive motor to open the door.

## SPRING SYSTEM

Depending on the size of the door, up to six springs are used. Springs are arranged in spring packs assemblies consisting of one, two, or three springs. A nylon strap attached to the upper end of each spring pack connects the pack to the drive shaft located in the console assembly. (See Figure 33.)

*NOTE: The larger S-size doors may have two straps containing up to a maximum of two spring packs with three springs each.*

*Two spring packs of three in each side column is the maximum.*

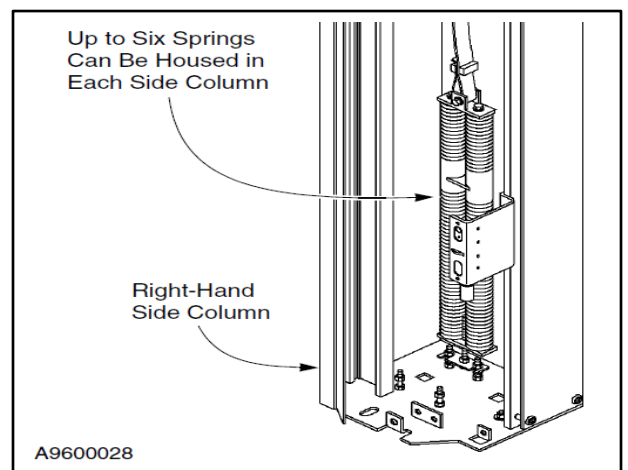


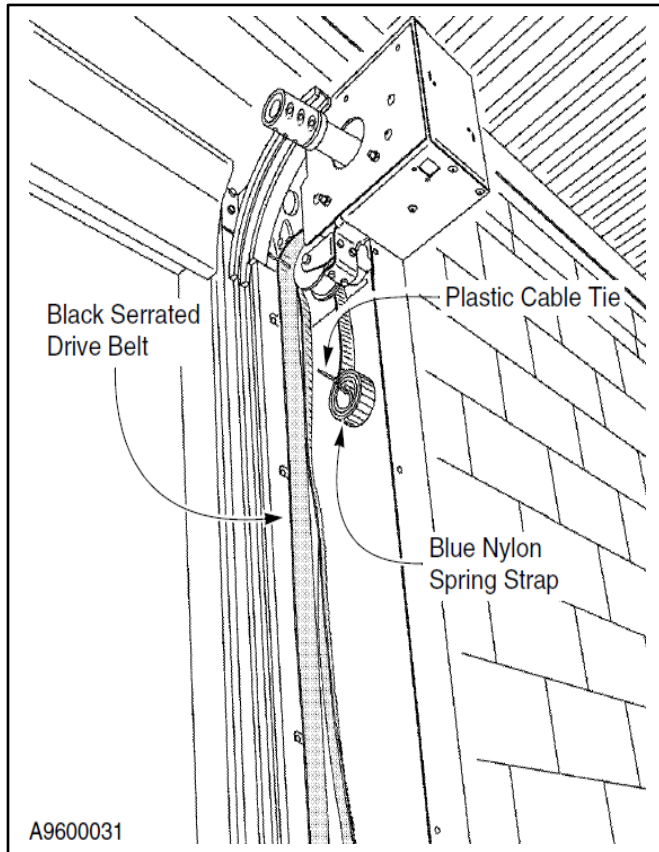
Figure 33



## SPRING PACK AND DRIVE BELT

1. Locate the blue nylon spring strap on the end of the drive shaft. To lower the strap through the side column, first carefully cut the plastic cable tie securing the strap to the drive assembly. (See Figure 34.)

**NOTE:** Each spring pack has its own dedicated nylon spring strap. The number of pre-wraps are predetermined at the factory for the proper door timing. **DO NOT** unwind any of the strap from around the drive shaft. Verify the number of wraps using the **packing sheet provided with the door.** (See Figure 38.)



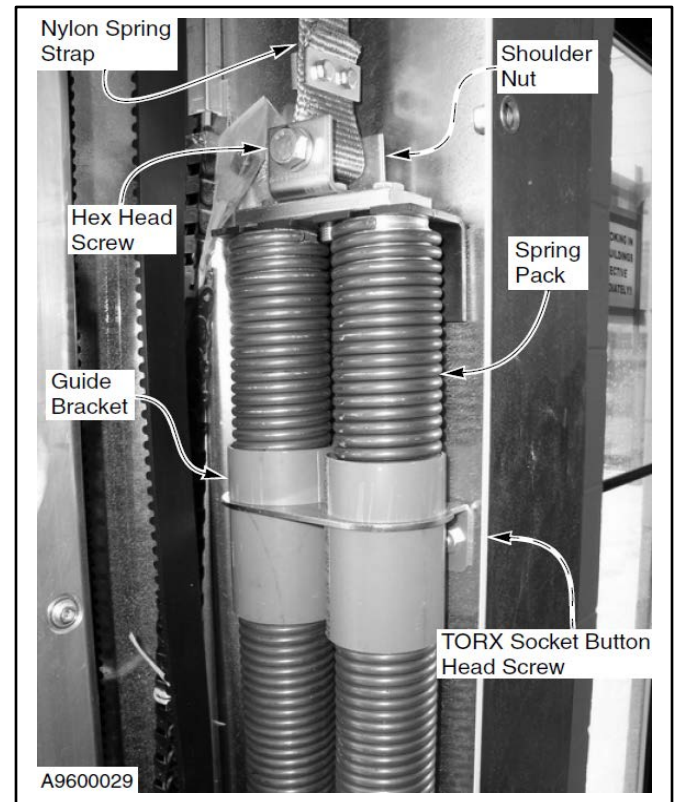
**Figure 34**

2. Hang each spring pack assembly from its associated spring strap. Make sure the nylon straps are not twisted. Use the hardware provided with the spring pack to attach the strap to the pack. (See Figure 35.)

**NOTE:** Spring packs have a special guide bracket for mounting the spring pack to the side column.

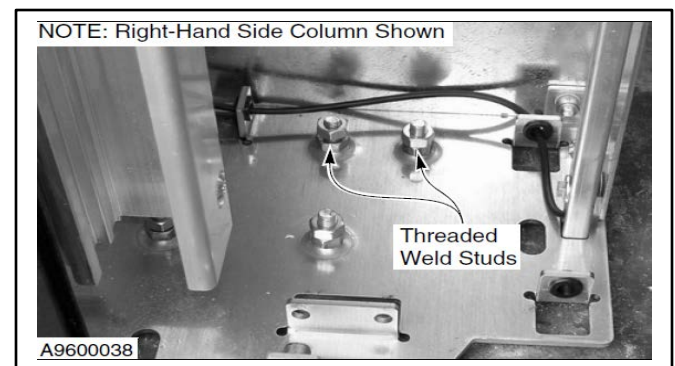
3. With the spring packs attached to the straps, mount the spring packs (with guide bracket) to the side column. Two TORX® socket button head screws, located in the small parts carton, are used to attach the spring pack to the side column. (See Figure 35.)

**NOTE:** Screw into guide from outside the side column.



**Figure 35**

4. Locate the two threaded weld studs with nuts mounted to the base plate. Check the bottom set of nuts to be sure they are tight and loosen the top set of nuts. (See Figure 36.)

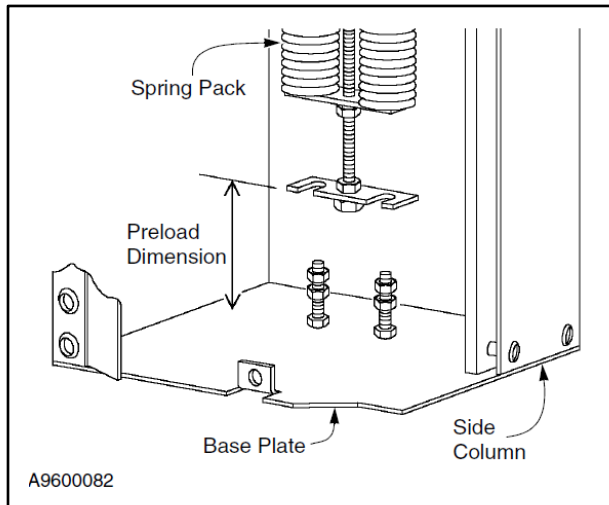


**Figure 36**



5. Preload dimension will adjust the spring to a preset tension before securing the spring packs to the base plate. That measurement is from the base plate to the forked plate on the spring pack. (See Figure 37.)

*NOTE: On the end of the adjustment rod is a forked mounting plate. It is used to attach the spring pack to a pair of mounting posts on the base plate. A pair of nuts on each post locks the spring pack to the plate.*



**Figure 37**

# SAMPLE PACKING SHEET

## SAMPLE PACKING SHEET

RYTEC CORPORATION ONE CEDAR PARKWAY JACKSON, WI 53037-0403 800-628-1909	DATE 06/10/13 DOOR NUMBER 123217 CUSTOMER SAMPLE
--	--

P R O D U C T I O N   D O O R   S I Z E

INSTALL THIS SPIRAL DOOR USING THE FOLLOWING DIMENSIONS

DOOR WIDTH 135.03 IN or 3430 MM  
DOOR HEIGHT 100.00 IN or 2540 MM

S P R I N G   P A C K ( S )   Q U A N T I T Y   L A Y O U T

TOTAL SPRING QUANTITY: 04

SPRING LENGTH: 051.88 IN  
1318 MM

SPRING PACK ASSEMBLIES TO BE INSTALLED  
IN THE FOLLOWING SIDE COLUMN POSITIONS

SIDE COLUMN POSITION	LH OUTER	LH INNER		RH INNER	RH OUTER
SPRING QTY	2	0		0	2

S P R I N G   P R E - T E N S I O N   S E T T I N G S

SPRING INITIAL TENSION: 03.4 IN  
0088 MM

SPRING STRAP DEADWRAPS: 02 WRAPS

NOTES!

1. DISCONNECT POWER FROM DOOR BEFORE ADJUSTING SPRINGS
2. ADJUST WITH DOOR FULLY OPEN AND MOTOR BRAKE APPLIED
3. MAKE SURE BLUE SPRING STRAP IS WRAPPED AROUND THE TOP SHAFT TO THE CORRECT NUMBER OF DEADWRAPS
4. USE SAME TENSION FOR ALL SPRING PACKS
5. SEE INSTALLATION MANUAL FOR FURTHER INSTRUCTIONS

RYTEC PART NUMBER: 0915007

Figure 38

## DRIVE BELT AND GUIDE PULLEY SYSTEM

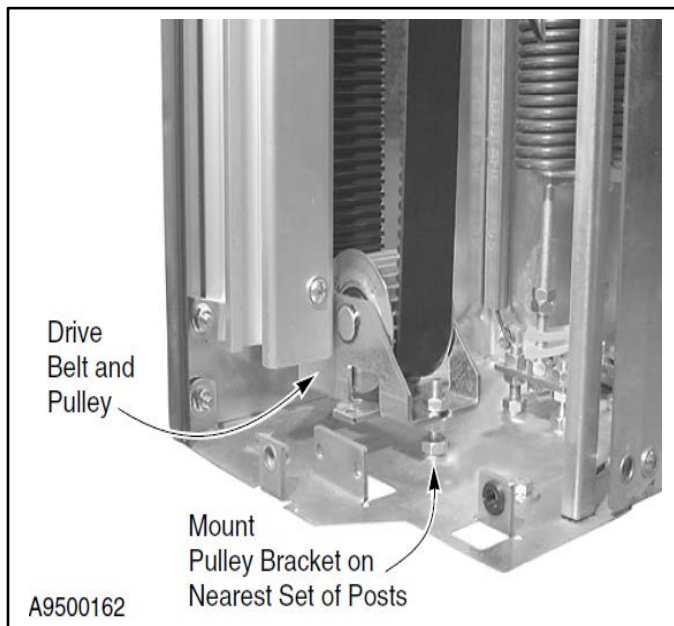
### Drive Belt and Guide Pulley System

The drive belt used to raise and lower the door can now be installed in each side column.

1. Each drive belt has been factory mounted to a drive pulley and a guide pulley. Also, each belt has been packed for shipping inside its respective drive assembly. Carefully cut the plastic cable tie that is temporarily securing the belt to the drive assembly.

*NOTE: Leave both drive belts on the drive shaft pulley in the position found. Do not re-index either drive belt on the drive shaft. Otherwise, the "timing" of the door travel will be affected, which could result in damage to the door.*

2. Pass the belt, along with the guide pulley, down the side column.
3. The nearest pair of mounting posts on the base plate is used for mounting the guide pulley. Remove the two upper nuts from the set of posts to make it possible to place the pulley. (See Figure 39.)



**Figure 39**

4. Secure the pulley bracket to the base plate using only the back post. Position that end of the pulley as close to the base plate as possible.

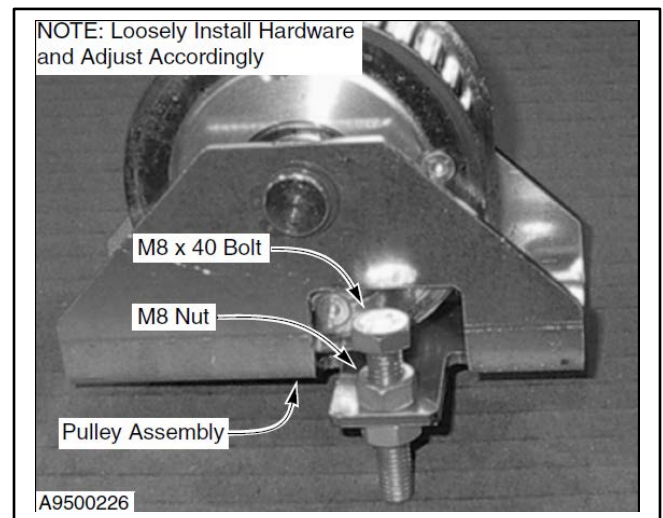
Depending on the length of the drive belt, the position of the lower nut along the back post can vary. Tighten the upper nut against the pulley bracket to lock the back of the pulley to the base plate.

5. The front post is used to set the tension on the drive belt. Thread the upper nut down against the pulley bracket until the belt is properly tensioned. Tighten the lower nut against the bottom of the pulley to lock in the tension. (See Figure 41.)

*NOTE: If you find it difficult to reach the front post with the pulley, give the belt some slack by repositioning the pulley bracket on the back post. Also, it is important that the pulley bracket be level (side to side).*

*If the pulley bracket is too short to reach the baseplate mounting post in the side column, the guide pulley trolley in the console will have to be adjusted. See "Console Guide Pulley Trolley Adjustment" on page 24. After the installation of the baseplate pulley bracket, the tension on the guide pulley in the console should be reapplied.*

6. To make the belt run true, level the pulley assembly by installing one bolt and two nuts, which can be found in the small parts carton, on each tab of the guide pulley bracket. (See Figure 40.)



**Figure 40**

7. Level pulley assembly, as required, and tighten hardware. (See Figure 41.)



**Be sure that the guide pulley bracket is level when the door is in operating mode. Damage to the belt or pulley components may occur if the guide pulley bracket is not level.**

## CONSOLE GUIDE PULLEY TROLLEY ADJUSTMENT

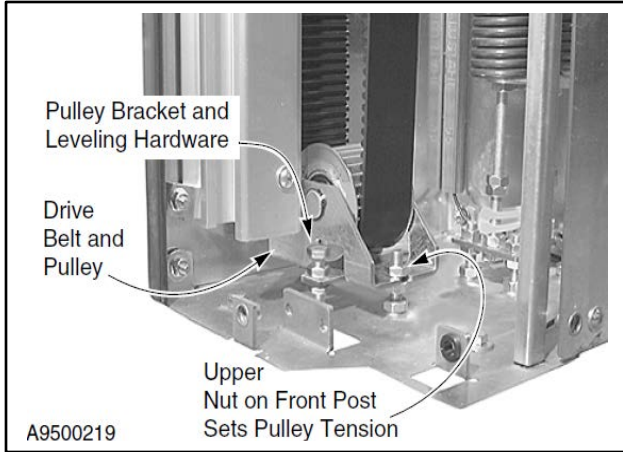


Figure 41

### Console Guide Pulley Trolley Adjustment

The drive belt guide pulley trolley within a drive or non-drive console can be adjusted fore and aft. This allows extra slack in the drive belt system if the guide belt pulley in the bottom of a side column cannot be installed. This should not be construed as the proper procedure in adjusting the drive belt.

*NOTE: Doors that are 13 ft. x 13 ft. (L-size) and smaller have only one adjusting screw for the trolley. Doors larger than 13 ft. x 13ft. (S-size) will have two adjusting screws for the trolley.*

*For consoles that have two adjusting screws, both screws should be adjusted and, when finished, should have contact with the pads on the trolley.*

*After installation of the baseplate pulley bracket, the tension on the guide pulley in the console should be applied.*

### CONSOLE – SINGLE ADJUSTING SCREW (L-SERIES)

1. Remove front cover to non-drive console.

*Note: On the drive console, there is no panel to remove to access the adjusting screw.*

2. Loosen the two nuts on the side of the console. (See Figure 42.)

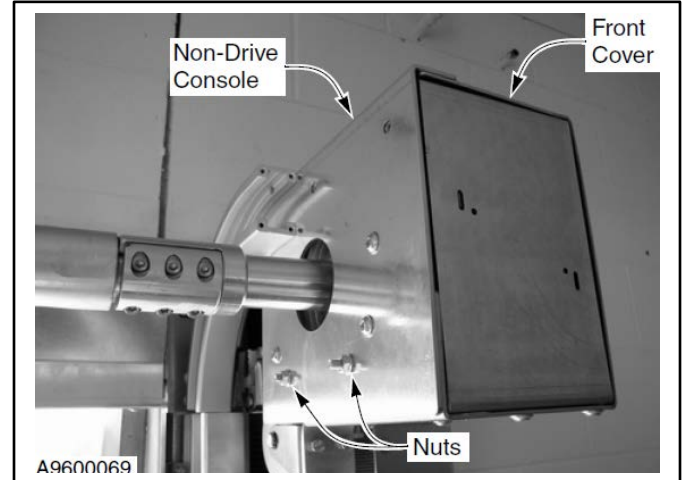


Figure 42

3. Loosen the two TORX® socket button head screws on the bottom of the console. (See Figure 43.)

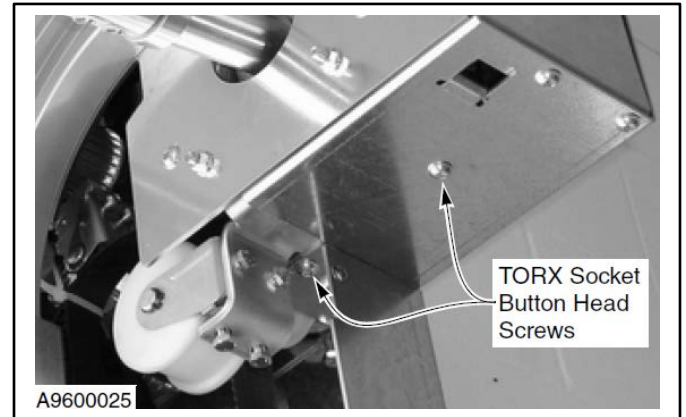


Figure 43

4. Turn cap screws to adjust guide pulley trolley. (See Figure 44.)

*NOTE: Turn cap screw clockwise to move the trolley toward the wall. Turn cap screw counterclockwise to move the trolley away from the wall or toward the front of the console.*

## CONSOLE GUIDE PULLEY TROLLEY ADJUSTMENT

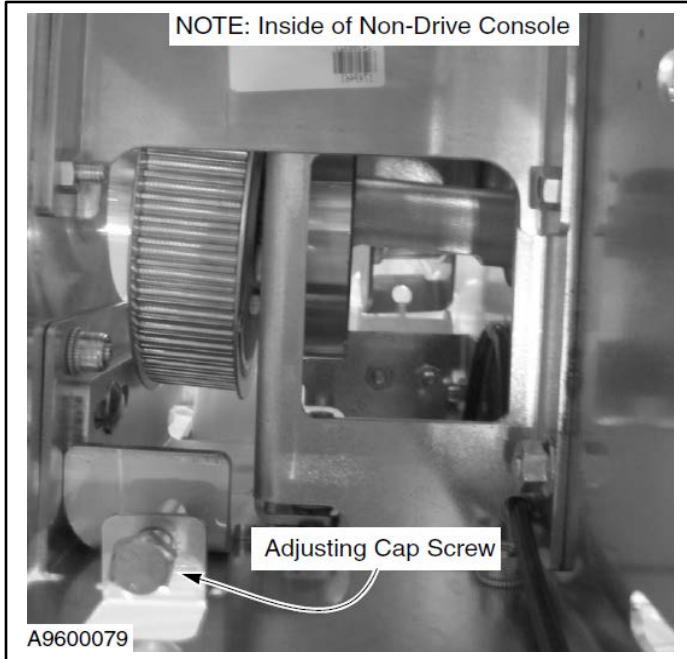


Figure 44

5. When the desired position of the trolley has been achieved, tighten the hardware and reinstall the front cover.

### CONSOLE – DUAL ADJUSTING SCREWS (S-SERIES)

1. Remove front cover to non-drive console.

*NOTE: On the drive console, there is no panel to remove to access that adjusting screw. The belt cover needs to be removed to access the bolts for the guide pulley trolley.*

2. Loosen the two nuts on the side of the console. (See Figure 45.)

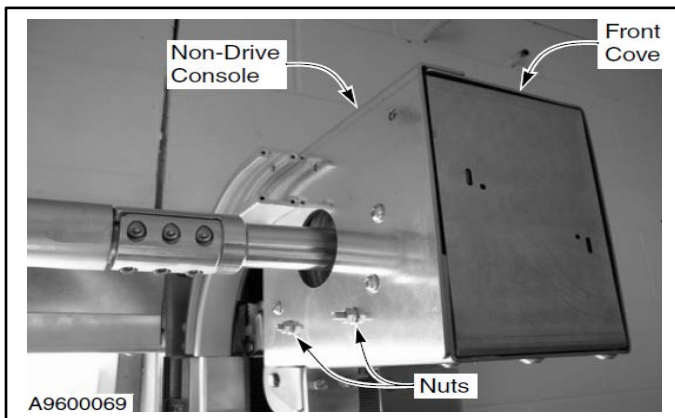


Figure 45

3. Locate the two holes on the opposite side of the console and loosen the bolts to the guide pulley trolley. (See NOTE.)

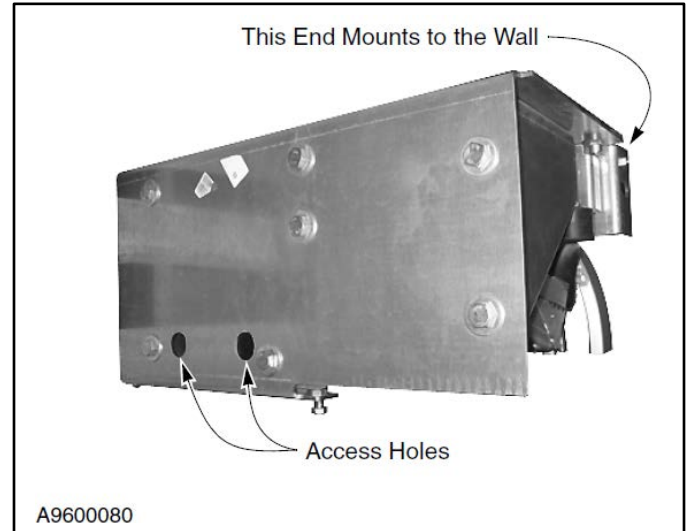


Figure 46

*NOTE: On the drive console, remove the belt cover to locate the two access holes and loosen the bolts to the guide pulley trolley. (See Figure 47.)*

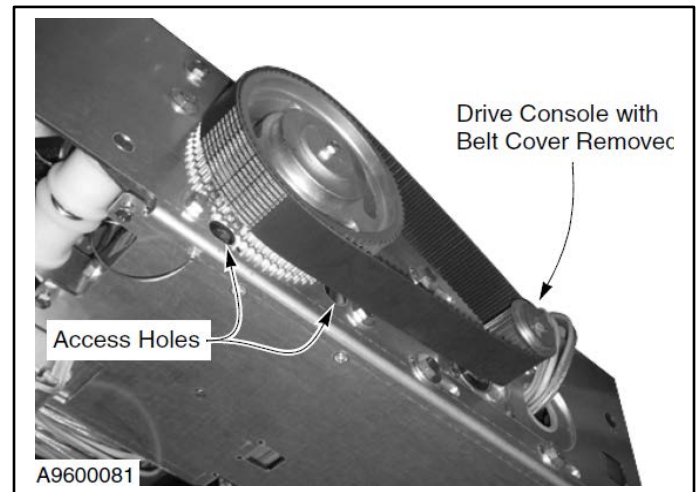


Figure 47

4. Turn the cap screws and adjust the guide pulley trolley.

*NOTE: Turn cap screw clockwise to move the trolley toward the wall. Turn cap screw counterclockwise to move the trolley away from the wall or toward the front of the console.*

5. When the desired position of the trolley has been achieved, tighten the hardware and reinstall the front cover.



# HORIZONTAL GUIDE RAILS

## HORIZONTAL GUIDE RAILS

*Note: The door comes from the factory with a set of brackets designed for multi-platform installation. Should the factory brackets be unsuitable for the application, the installer will be responsible for custom fabrication of brackets based on the requirements of the installation.*

1. Confirm that guide pins are installed in the horizontal guide rail. (See Figure 48.)

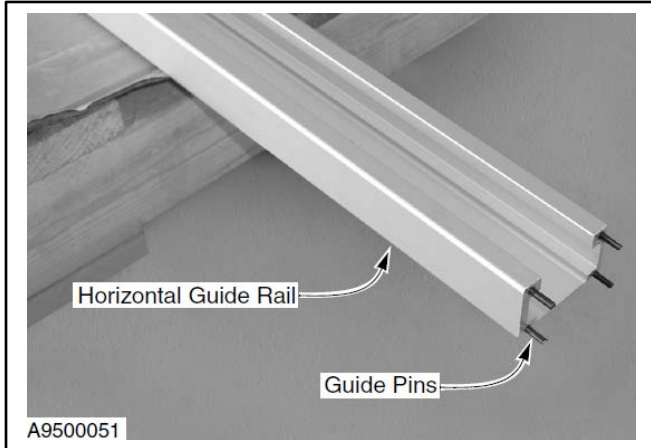


Figure 48

2. Insert the horizontal guide rail into the console. Install the hardware and secure the rail to the console. (See Figure 49.)

**IMPORTANT:** When installing hardware, make sure the head of the bolt is inside the guide rail, or interference may cause damage to the rollers when the door operates.

*NOTE: Support the opposite end of the guide rail while performing this installation.*

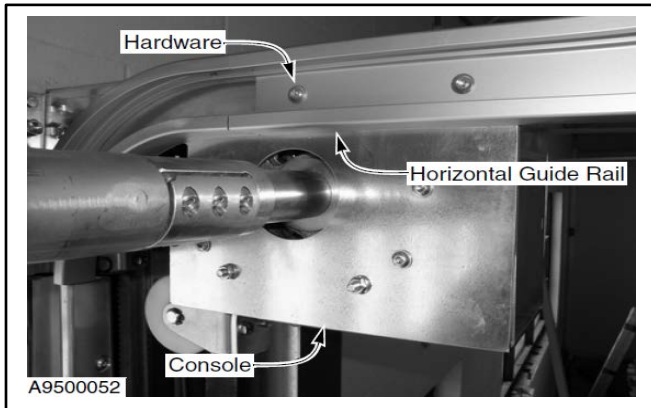


Figure 49

3. Support the end of the guide rail with rope or a mechanical device. Place a carpenter's level on top of the guide rail and secure the guide rail in a level position. (See Figure 50.)

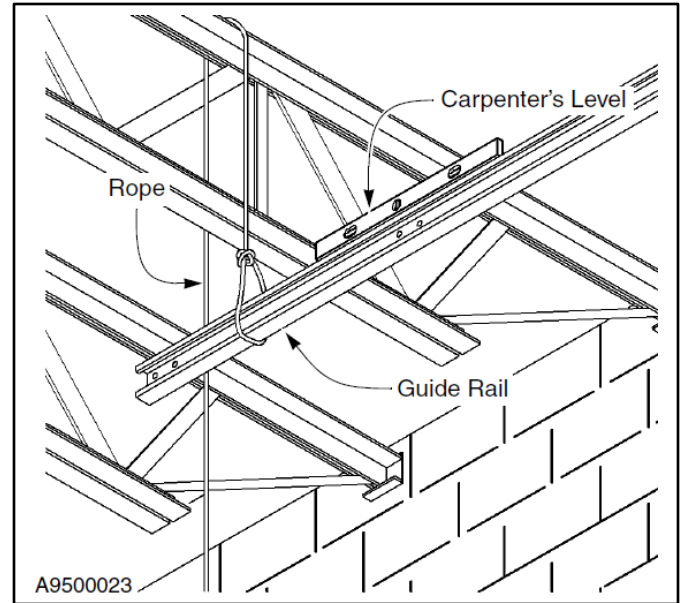


Figure 50

4. Install the ceiling mounting brackets. (See Figure 51.)

*NOTE: The horizontal guide rail has factory pre-drilled holes for mounting the ceiling brackets, two for each side. Custom fabrication of the brackets and drilling of extra mounting holes may be required to facilitate installation.*

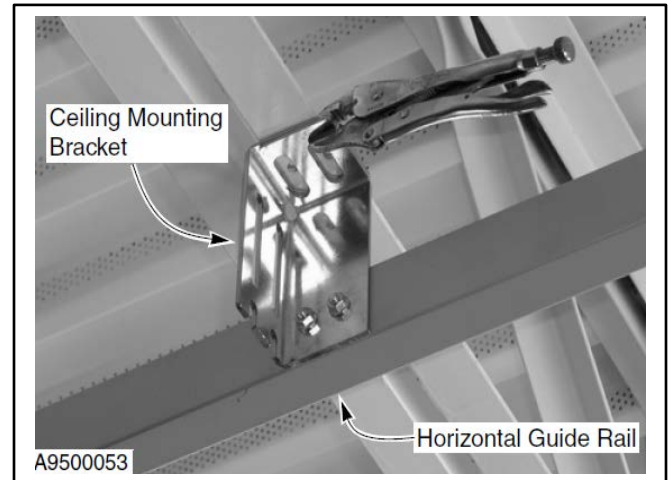
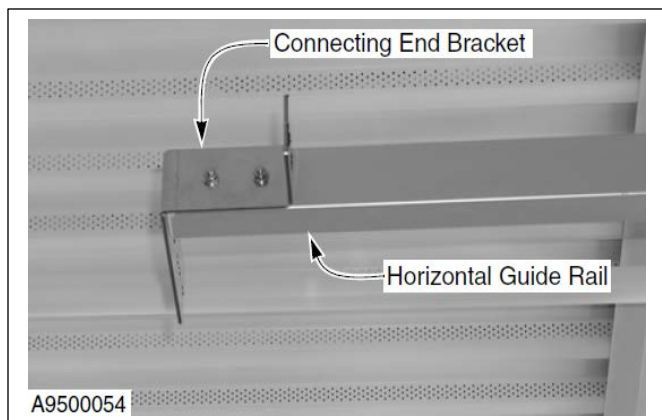


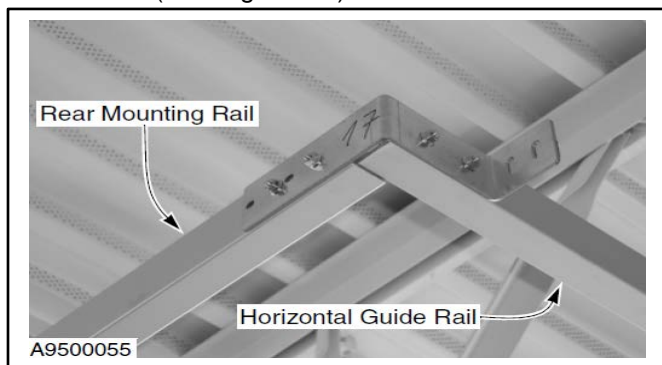
Figure 51

5. Install the connecting and bracket to both horizontal guide rails. (See Figure 52.)



**Figure 52**

6. Install the rear mounting rail and ceiling mounting bracket. (See Figure 53.)



**Figure 53**

7. Confirm that the horizontal guide rails are still level and all hardware is tight and secure.
8. Check that the overhead rail assembly is square and in proper alignment. (See "FINAL ADJUSTMENTS" on page 40.)

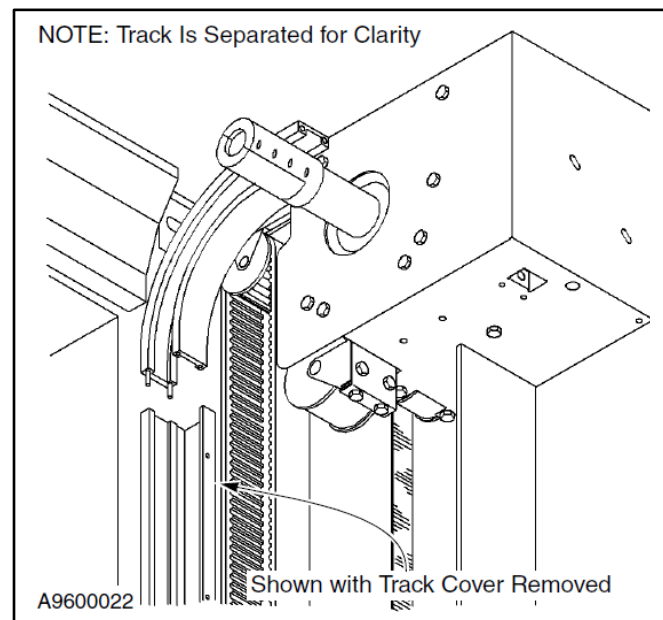
## DOOR PANEL



**Caution:** The door panel assembly is extremely heavy. To prevent personal injury or damage to the door panel, the use of a mechanical lifting device or forklift is required for installation.

1. Prior to installation, confirm that the side columns, rear spreader, consoles, connection shaft, and horizontal guide rails are secure and hardware is tightened.
2. Remove the track cover. (See Figure 54.)

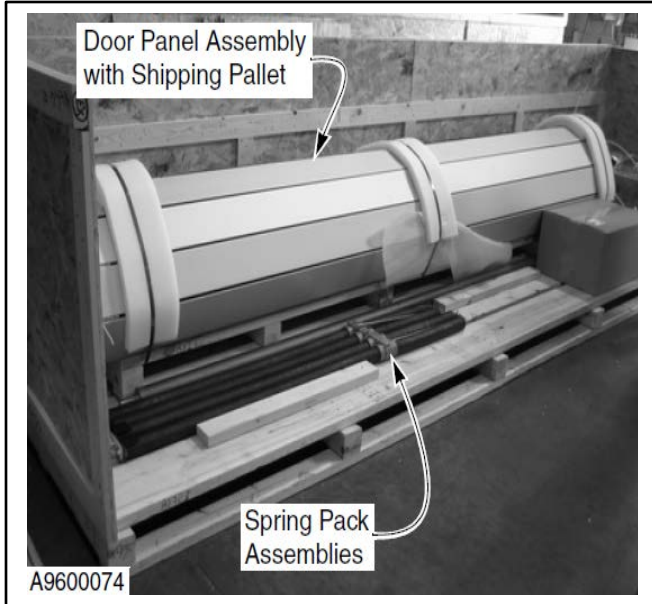
*NOTE:* Depending on the height of the door, the track cover may be a one-, or two-piece unit. If it is a two-piece unit, the top half track cover should be removed as shown in Figure 54.



**Figure 54**

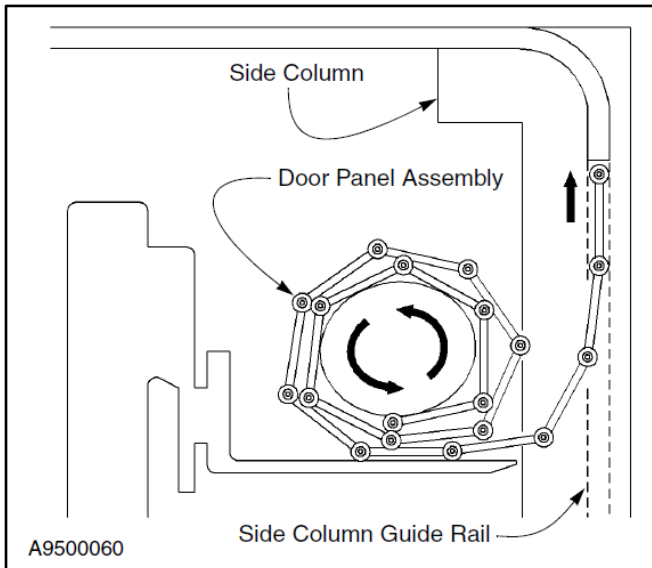
3. Remove door panel assembly from the crate using the shipping pallet that the panel is strapped to and make a general inspection of the door panel. (See figure 55.)

## BRAKE RELEASE



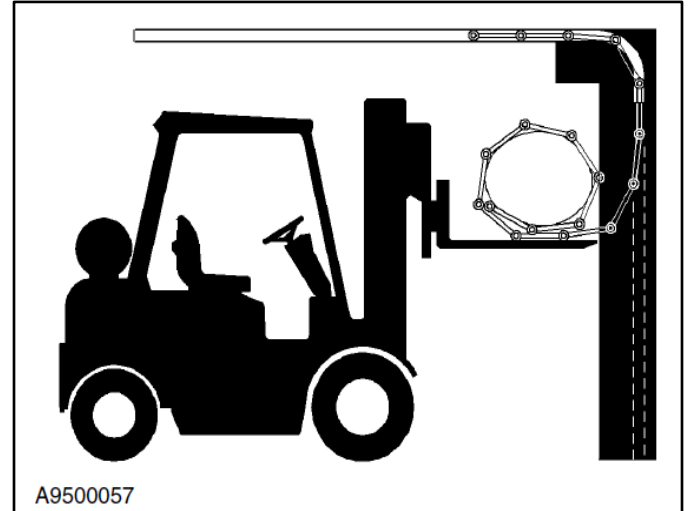
**Figure 55**

4. Center the door panel assembly on the forks and align the panel in the center of the opening.
5. Position the pallet and panel on the forks so that the door lip is facing the side column guide rails (See Figure 56.)



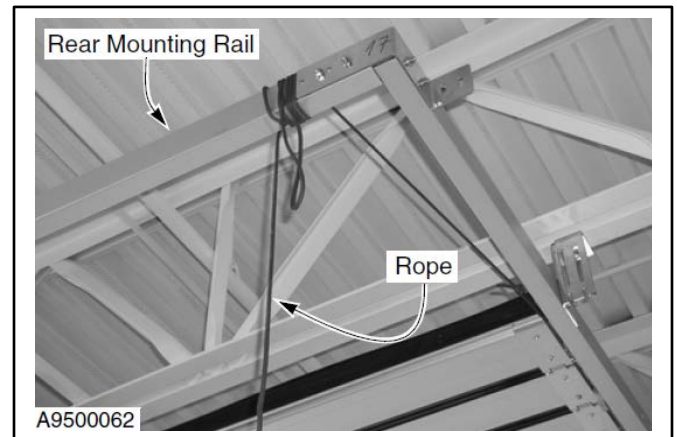
**Figure 56**

6. Guide the rollers of the door into the guide rail system. (See Figure 57.)



**Figure 57**

*NOTE: The use of a rope might be required to secure the door while trying to insert rollers into the rail system. The rope must be tied to both ends of the door panel. Run the ropes over the connecting shaft and pull the door panel into the guide rails. (See Figure 58.)*



**Figure 58**

7. Secure the door panel to the rear mounting rail and install the upper half of the track cover.

## BRAKE RELEASE

This Rytec door is equipped with a brake override system that allows the door to be manually opened or closed in the event of an emergency or power outage. A steel cable links the electrical brake mechanism, located just above the drive motor, to a brake release handle mounted on the left-hand side column.

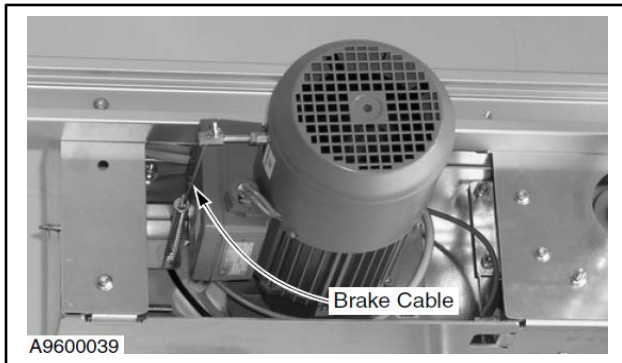
When the brake release has been engaged, the door should automatically lift to about a third to one half open.



## DOOR PANEL TO DRIVE BELT L - SIZE

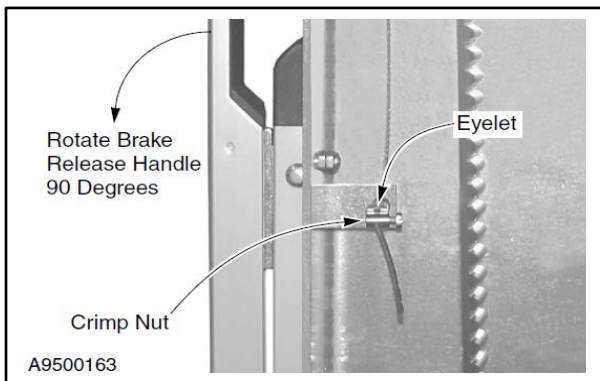
1. One end of the steel cable was connected to the brake mechanism at the factory. For shipping, the other end has been routed out through the side of the drive console. Pull the cable back through the console assembly and route it down through the side column to the brake release handle. (See Figure 59 and Figure 60.)

**NOTE:** Tug on the free end of the cable to check that it is not caught or hung up.



**Figure 59**

2. With the brake release handle fully extended out or at 90 degrees, feed the cable through the eyelet in the bottom of the handle. Slide a crimp nut over the end of the cable with the nut tight against the eyelet. Then tighten down the set screw – with most of the slack removed from the cable. The crimp nut is located in the small parts carton. (See figure 60.)



**Figure 60**

3. Pull the handle several times to stretch the cable and remove any slack. Check the action of the lever on the brake mechanism for proper travel. If necessary, reposition the crimp nut.

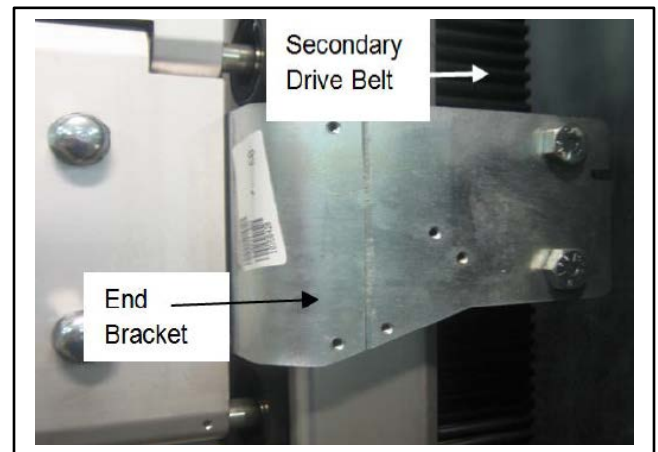
**NOTE:** Be sure that the cable isn't so tight that the brake mechanism cannot re-engage once the lever is released and put back in place.

4. Cut the cable to length, 2 in. after the crimp nut.
5. Disengage the electric brake by pulling the brake release handle. Then manually lower the door a few inches to verify that the door is not bound or caught up in the head assembly.
6. To re-engage the electric brake to lock the door in place, place the brake release handle back against the side column.

## DOOR PANEL TO DRIVE BELT L-SIZE

The following procedure can be performed without either the power or the control panel connected as explained below. Should the panel be fully operational, set the System 4 in "JOG MODE" (Refer to System 4 Drive & Control Installation & Owner's Manual) and lower the belt accordingly.

1. Release the brake to the drive motor assembly.
2. Pull on the drive belt and align the splice block with the door bracket.
3. Install hardware, connecting the door bracket to the splice block in each side column. (See Figure 61.)



**Figure 61**

**NOTE :** The end bracket and splice block will have a similar configuration.

4. Remove the ropes holding the panel and engage the brake.

## DOOR PANEL TO DRIVE BELT S - SIZE

### DOOR PANEL TO DRIVE BELT S-SIZE

1. Cut the cable tie holding the belt in the consoles.
2. Drop the belt down the side columns.
3. At the bottom of the S-size doors the pulley is incorporated into the base plate. (See Figure 62.)

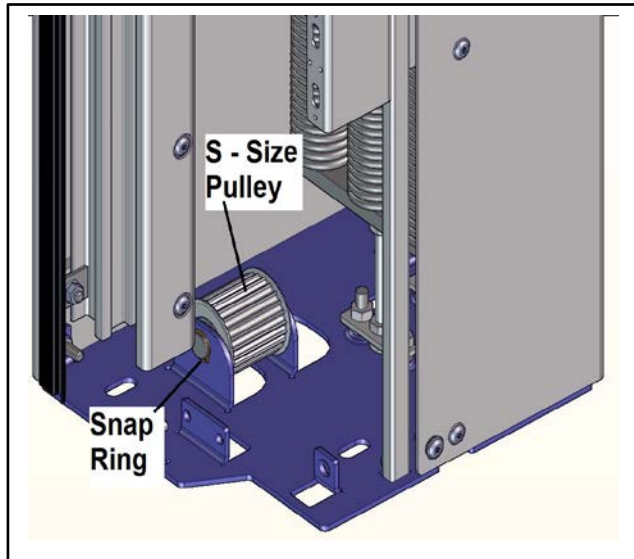


Figure 62

4. Remove one of the snap rings from the end of the pulley shaft.
5. Push the shaft through the center of the pulley and remove the pulley. (See Figure 63.)

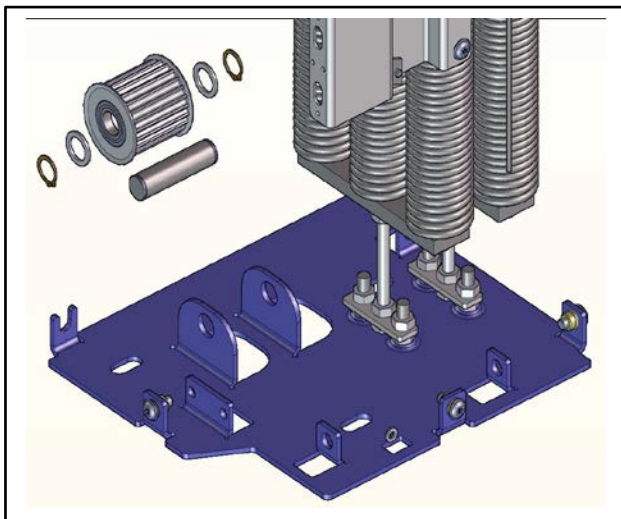


Figure 63

6. Place the pulley inside the loop of the belt and re-assemble the pulley hardware in the bottom plate. (See Figure 64.)

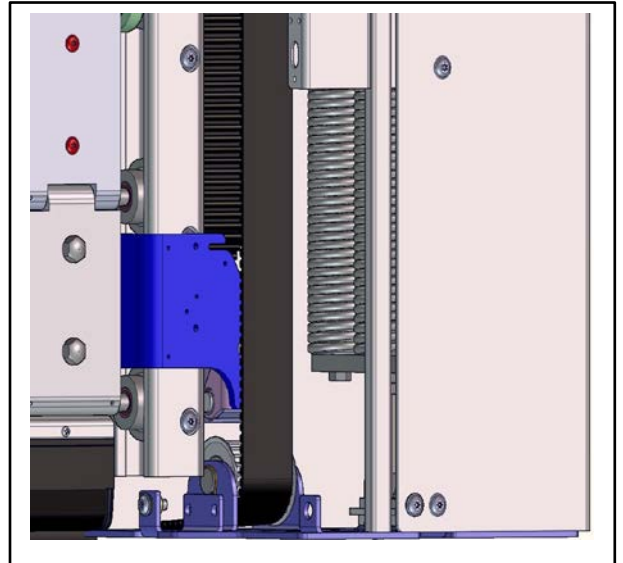


Figure 64

7. Repeat the process for the opposite side column.

## PHOTO EYES

This door uses two sets of photo eyes to monitor the front and back sides of the door. Each set consists of two photo eye modules. The factory-installed eyes are located in the left - front and right - front corners of the door. The customer-installed eyes are to be located in the left - rear and right - rear corners of the door. (See Figure 65.)

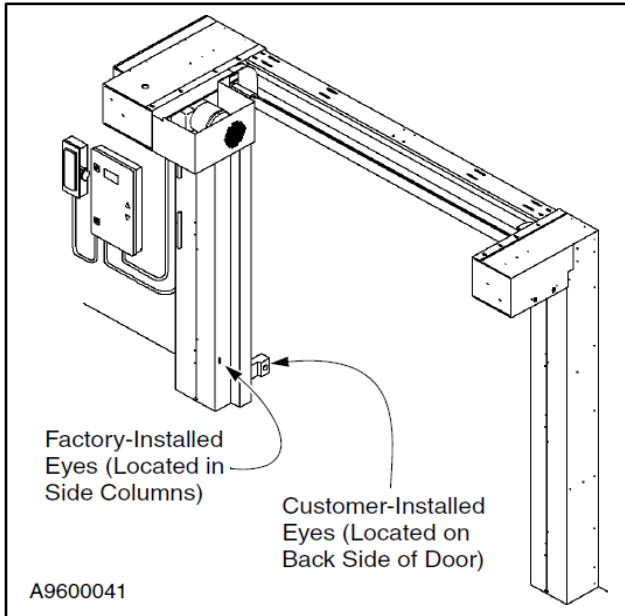


Figure 65

### Factory – Installed Eyes

1. Locate each factory – installed photo eye module and its required wire cable. (See Figure 66.)



Figure 66

2. Each cable has been routed up through a vertical raceway located in the corner of the side column. Locate the free end of each photo eye cable. (See Figure 67.)

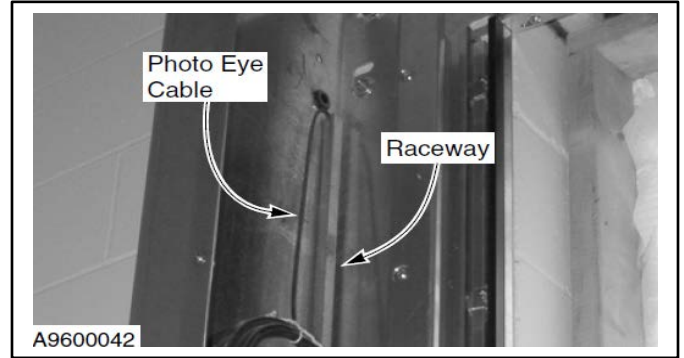


Figure 67

3. Route the right – front photo eye cable straight up into the right console assembly, then across the rear spreader. This rear spreader runs between the side columns along the top. (See Figure 68.)

Check to make sure the cable is lying on top of the rear spreader. Later, once all wiring is complete, plastic cable ties will be used to keep the cables on the rear spreader.

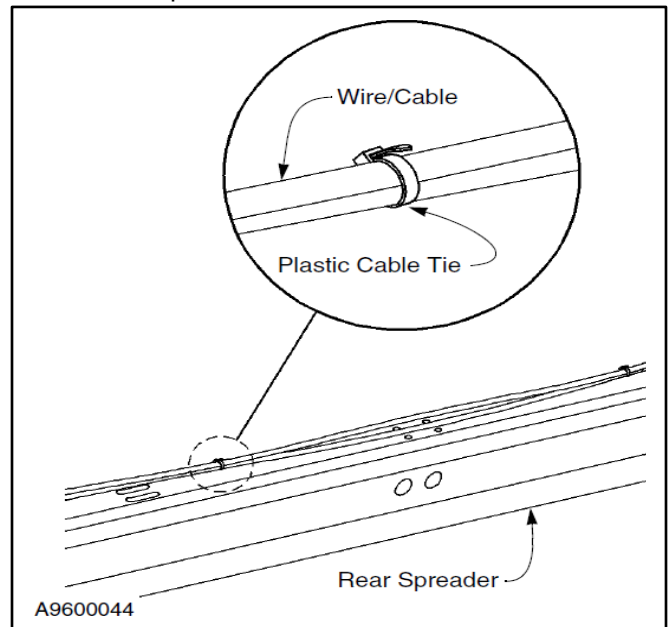
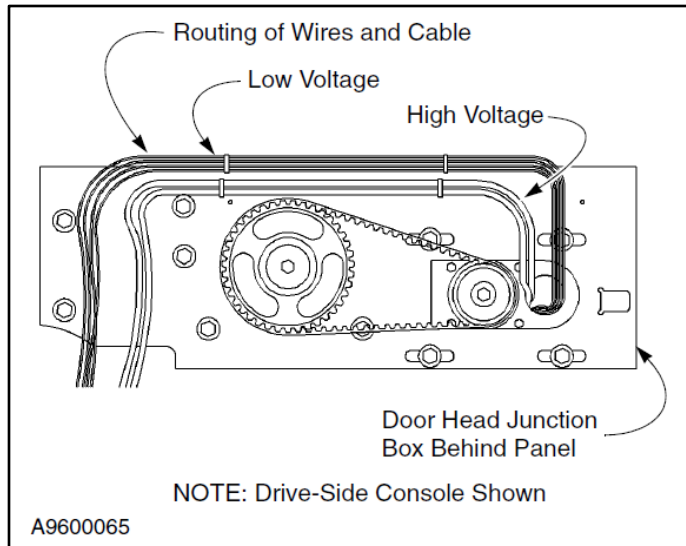


Figure 68

4. Continue routing this cable through to the left console assembly and over to the door head junction box, located behind a panel on the drive side console. (See Figure 69.)

**NOTE:** Route cable away from all belts and pulleys. Separate high – and low-voltage cables to prevent signal interference.

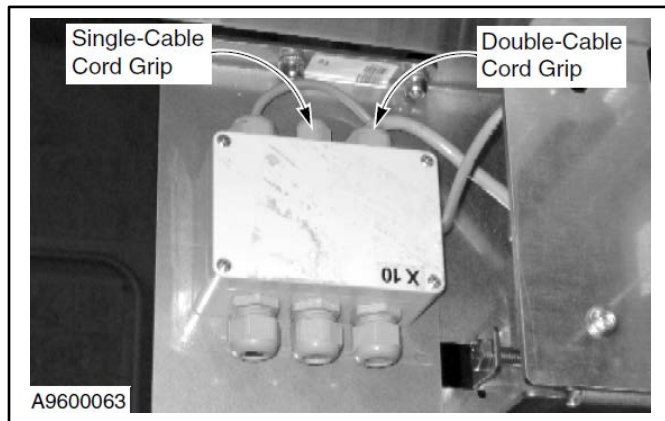
## FACTORY INSTALLED PHOTO EYES



**Figure 69**

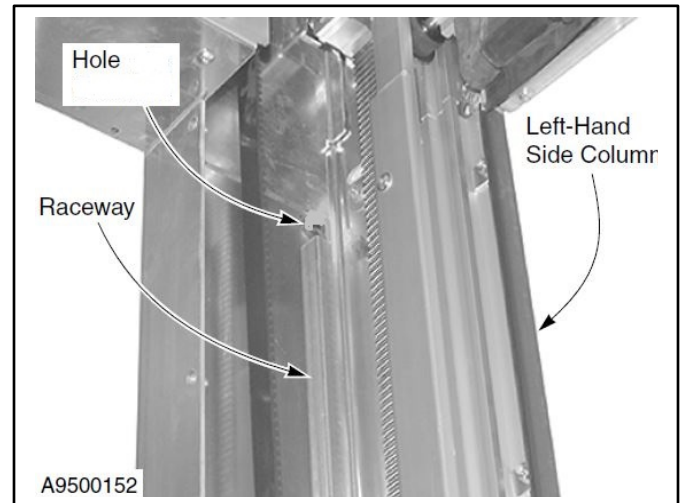
- Remove the junction box cover and save the hardware for later use. Then pass the cable through the double-cable cord grip on the side of the junction box. Do not tighten the cord grip at this time. (See Figure 70.)

*NOTE: Take note that the two available cord grips are different – one is a single-cable grip, the other a double grip.*



**Figure 70**

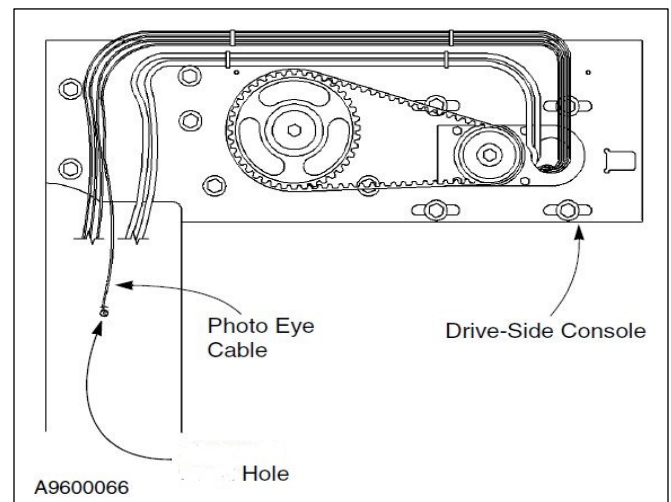
- Route the left - -front photo eye cable out the hole near the back of the drive console. This hole is located just above the raceway. (See Figure 71.)



**Figure 71**

- From the hole, pass the photo eye cable into the drive-side console and over to the door head junction box. (See Figure 72.)

*NOTE: Make sure to route the wire cable away from all belts and pulleys. Separate high- and low-voltage cables to prevent signal interference.*



**Figure 72**

- Pass the second photo eye cable through the double-cable cord grip. Tighten the cord grip to lock both photo eye cables to the junction box. (See Figure 70.)
- Connect the control lines for the factory-installed photo eyes to the door head junction box as indicated on the electrical schematic shipped with the System 4 control.



### Customer-Installed Eyes

To monitor the back side of the door, a second set of photo eyes must be installed. These eyes, their required cables, and two mounting brackets are located in the small parts carton. You must provide the necessary hardware to install the brackets on your particular wall.

*NOTE: The rear set of eyes is to be located on the back side of the door, approximately 12 in. above the front set of eyes and as close to the door opening as possible. It is also important that the eyes are mounted directly across from each other.*

*In addition, note that the front and rear sets of eyes and their associated cables are of different styles. The eyes and cables are not interchangeable.*

1. After the mounting brackets are in place, mount the emitter module in the left-rear mounting bracket and the receiver module in the right-rear bracket.

The receiver module can be identified by the SMR and yellow LED lit when aligned. The emitter module SMT has a green LED when powered.

(See Figure 73.)

2. Using the two cables provided, route one cable from each photo eye to the control panel. At the factory, a string was routed through each side column to help pull the cables through the side columns. Remove both strings once the cables are routed.

*NOTE: Be sure the path through which the cables are routed hides and protects them from damage. If necessary, run conduit to each mounting bracket to protect the cables. Note the end of the cable intended for the photo eye. DO NOT connect the photo eye cables to the control panel at this time.*

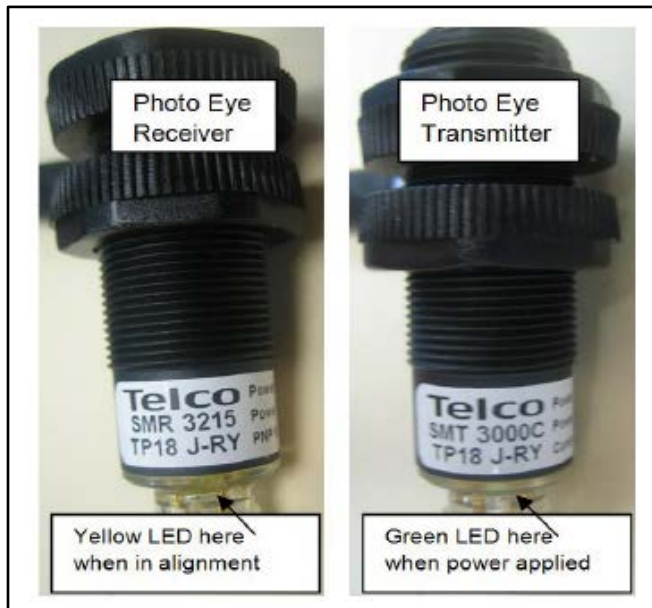


Figure 73

# WIRELESS ANTENNA BRACKET

## WIRELESS ANTENNA BRACKET

The Spiral LH-HZ is equipped with a wireless reversing edge. The antenna is cable tied to the motor junction box with a piece of foam over the antenna quills for protection. (See Figure 74.)



Figure 74

1. Pre-assemble the Z shaped bracket to the larger wireless bracket. Use the shorter 12mm screws and the standard M4 hex nuts to attach. (See Figure 75 & 76.)

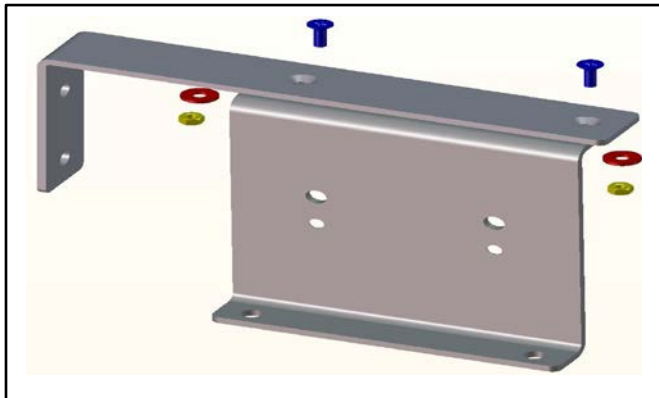


Figure 75

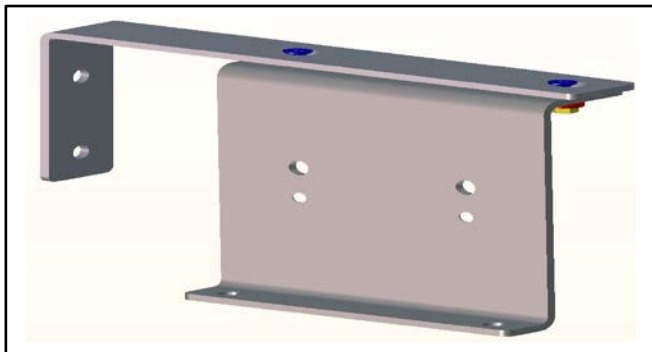


Figure 76

NOTE: Right hand drive opposite left.

2. Attach the assembled bracket to the console. (See Figure 77.)

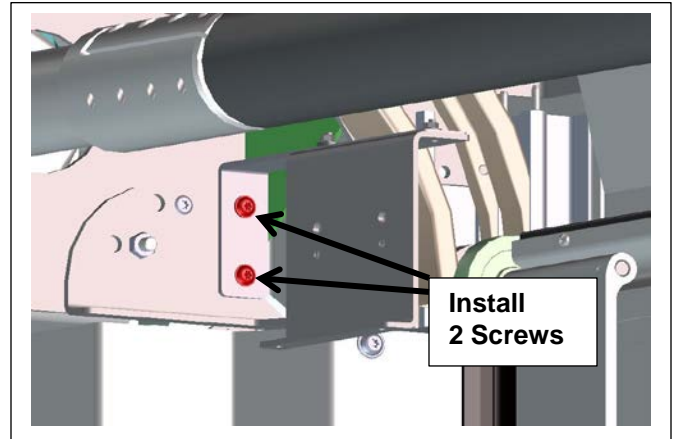


Figure 77

3. At this time find the wireless antenna attached to the motor junction box and cut it free from motor junction box. The antenna must be routed back through the console assembly. Pass the antenna through the opening near the motor and exit out the top of the side column. The tan cable needs to follow closely to the inside of the head assembly. Use cable ties to hold the cable away from moving objects. (See Figure 78.)

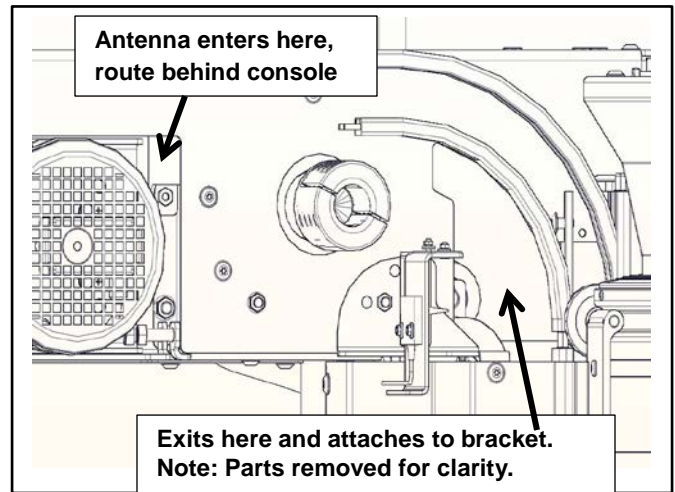


Figure 78

4. Attach the wireless antenna to the Z bracket using the longer screws provided with the washers and locking nut. DO NOT over tighten the screws or damage to the antenna could occur. The tan cable MUST exit towards the floor, from the antenna.

## CONTROL SYSTEM

Once the door has been assembled, see the Rytec System 4 Drive & Control Installation & Owner's Manual for information on control panel installation, electrical connections, and door limit settings.

*NOTE: To expedite the installation of this door, it is recommended that the electrical disconnect and control panel be installed prior to installing the door. Review the layout diagram shipped with your door to determine exactly where these major electrical components are to be located. The control panel and disconnect are typically mounted adjacent to the left side column.*

If you have any questions regarding this installation, contact your Rytec representative or the Rytec Technical Support Department at 800-628-1909.



Figure 79

## ⚠ WARNING

All electrical work must be performed by a licensed or certified electrician. All electrical work must be performed in accordance with all local and state building codes and requirements.

## ⚠ WARNING

The disconnect must be in the OFF position and properly locked and tagged before performing the following procedure.

**IMPORTANT: All high and low voltage cables must be installed in separate conduit, cut to length with no excess or loops.**

*NOTE: All wiring and required conduit between the electrical disconnect and the control panel, between the control panel and the small junction box near the drive motor, and between the control panel and the floor, must be supplied by the owner of the door. All wiring and conduit must meet all local and state building codes and requirements. Wires provided with the door have been identified with terminal or contact numbers.*

All conduit entering the control panel **MUST** enter from the bottom. **DO NOT** run any conduit into or through either the top or side of the control panel.

Protect the components inside the control panel from metal chips when installing the conduit. Seal the conduit where it enters the control panel – particularly if the conduit is routed from one area to another, where the two areas can have different ambient air temperatures. If the conduit is not sealed properly, condensation can form inside the control panel, which can lead to serious electrical problems.

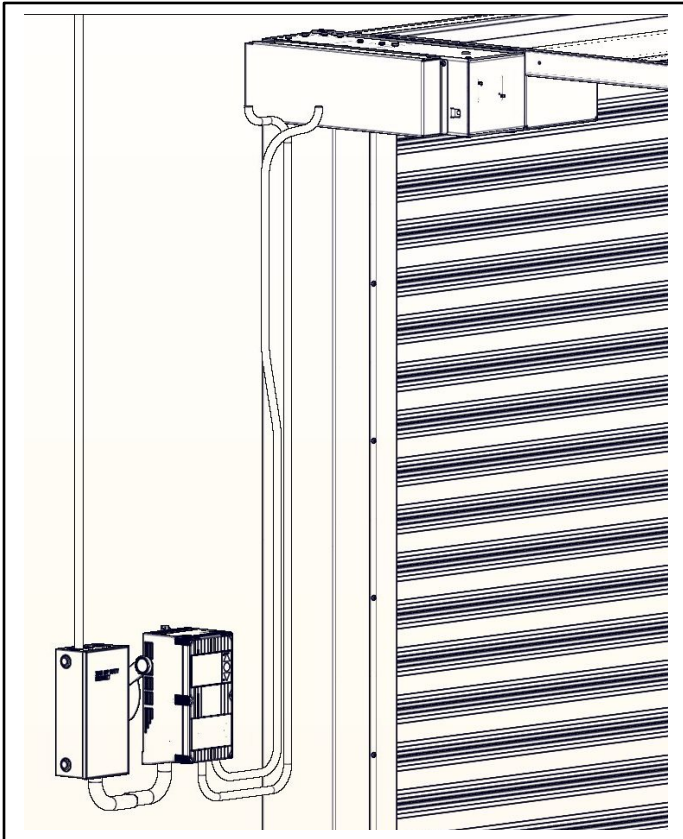
The wiring diagrams and schematics provided in this manual are for informational purposes only. Due to customer requirements for individual installations, a schematic diagram has been prepared for your particular door and installation. That schematic diagram has been prepared for your particular door and installation. That schematic diagram has been shipped with the control panel and must be referred to during this installation.

## CABLES TO CONTROL PANEL

### DRIVE MOTOR TO CONTROL PANEL

1. Route the drive motor/motor brake power cable, leading from the motor junction box, to the control panel. (See Figure 80.)

*NOTE: To properly ground the outer shield of this cable, terminate the end of the cable to the control panel using the grounded cable clamp provided.*

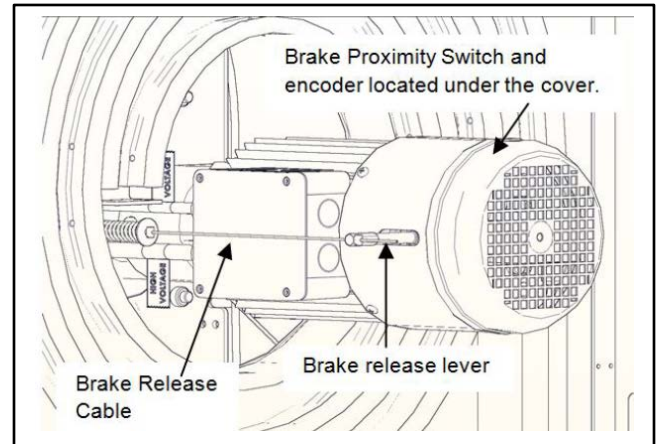


**Figure 80**

2. Connect the drive motor power supply lines to the control panel as indicated on the electrical schematic.
3. Connect the motor brake power supply lines to the control panel as indicated on the electrical schematic.

### BRAKE RELEASE SENSOR TO CONTROL PANEL

1. Route the brake release sensor cable, leading from the motor junction box, to the control panel. (See Figure 81.)

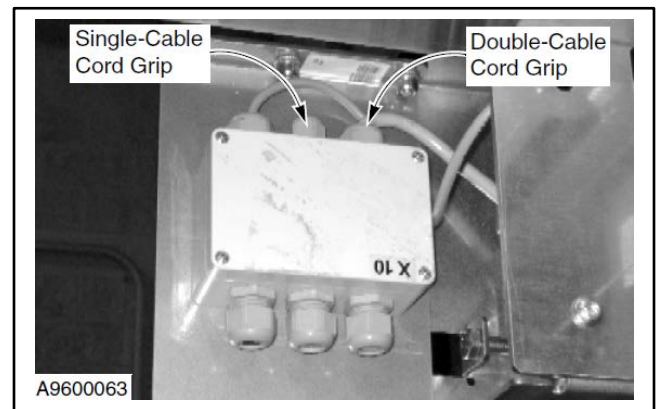


**Figure 81**

2. Connect the brake release sensor control lines to the control panel as indicated on the electrical schematic.

### FACTORY-INSTALLED PHOTO EYES TO CONTROL PANEL

1. Route factory installed photo eye control cables, leading from the door head junction box, to the control panel. (See Figure 82.)



**Figure 82**



### **CUSTOMER-INSTALLED PHOTO EYES TO CONTROL PANEL**

1. Earlier, the two control cables for the customer-installed photo eyes were routed from the eyes to the control panel. Now these control lines can be connected to the control panel as indicated on the electrical schematic.

### **ACTIVATORS**

Rytec recommends setting the limits on the door and operate the door initially without the activators connected. When the limits have been established and the door operated 20 times, then turn OFF the disconnect power and install the activators. Establishing the limits and operating the door allow you to isolate any potential operating issues to the door without the activators connected. Often activators create problems at initial start-up. Connect activators as shown on the schematics provided in the System 4 control panel received with the door.

## OPERATING CONTROL SYSTEM – INITIAL START-UP

### OPERATING CONTROL SYSTEM

The Spiral LH-HZ Door offers high-speed operation with the advantage of providing a secure barrier. All operator inputs and control functions are carried out by the “System 4” drive and control system. (See Figure 83.)



Figure 83

#### Modes of Operation

##### AUTOMATIC AND NON-AUTOMATIC MODES OF OPERATION

###### Automatic Mode

If a *momentary* contact activator such as a push-button, pull cord, radio, etc., is used to activate the door:

- The door will open when the device is activated.
- A timer, internal to the control system, will start up once the door reaches the full open position.
- When the internal timer clocks out, the door will automatically begin to close.

If a *maintained* contact activator device such as a floor loop, motion detector, etc., is used to activate the door:

- The door will open and remain open for as long as the device is active.
- Once the device becomes inactive, the internal timer will start up.
- When the internal timer clocks out, the door will automatically begin to close.

In the automatic mode, while the timer is running, at any time the activator device or another activator in the system is enabled, the timer will rest and the door will not be allowed to close. It is only when the timer clocks out that the door will begin to close. (To change the timer setting, see the “System 4 Drive & Control” manual.)

In summary, in the automatic mode, an externally installed activator device is used to open the door and an internal timer is used to close the door.

###### Non-Automatic Mode

If a momentary contact activator such as a push-button, pull cord, radio control, etc., is used to operate the door:

- The door will open when the device is activated.
- After passing through the door, a similar type of device must be used to close the door.

In summary, in the non-automatic mode, a manually-operated activator is used to open and close the door.

NOTE: The System 4 control has separate inputs programmed with or without the use of timers. Any input utilizing a timer can be turned OFF by simply reducing the time to 0 seconds. (See the “System 4 Drive & Control” manual.)

### INITIAL START-UP

NOTE: Once you have set your door limits during this procedure they are permanently stored.



**Initial system start-up is only to occur once the door and control panel have been properly installed, wired, and all preliminary door adjustments made. Failure to follow the instructions as outlined in the installation manual that was provided with your door can result in damage to the door upon initial system start-up.**

1. Release the brake with the handle located on the side column and manually move the door to the half-open position.

- Apply power to the control system. During the system initialization, the display will indicate that the door close and open limits must be set by displaying the associated fault codes (F700 and F762 will scrawl across the display). (See Figure 84.)

Then the message Push ● [press reset (●) key] will appear on the display. (See Figure 85.)

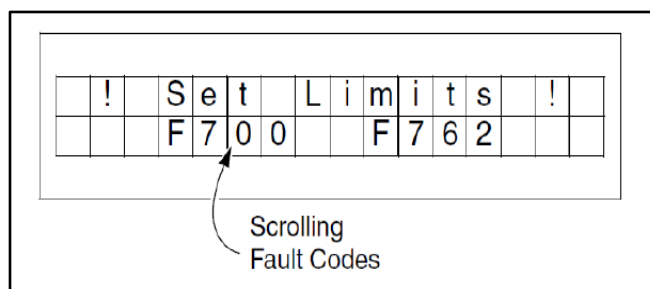


Figure 84

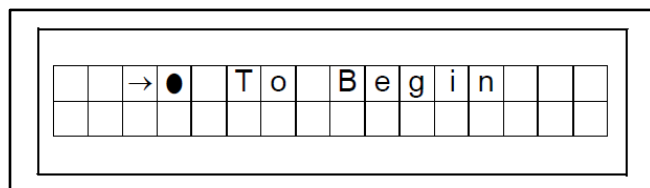


Figure 85



**The door open and close limits are to be set only after verifying that the motor (door) operates in the proper direction when the up (▲) and down (▼) keys are pressed.**

- After the reset (●) key has been pressed one time (Figure XX), verify the motor rotation by briefly pushing the up (▲) and down (▼) keys on the control panel.

The door should open with the up (▲) key and close with the down (▼) key. If the door does not operate in this manner, reverse two of the motor wires (not the incoming three-phase supply wires).

*NOTE: Reversing the incoming supply voltage lines will not solve the motor rotation problem. Switch the T1 and T2 motor leads.*

- Now set the door close and open limits according to the instructions on the display.

If any error messages are displayed, some of the required input connections may be missing. Once the missing inputs are connected, perform the close and open limit set-up. Otherwise, refer to “FAULT CODES” in the “System 4 Drive & Control” manual.

- After the limit positions have been set the door will automatically synchronize. During the automatic synchronization process the display will read “I:515, I:510” this is normal, **DO NOT** make any changes to the door until the 500 messages have left the screen, This could take up to 15 cycles to complete.

### System Reset – Door reversing Edge

Any time the door is closing and the reversing edge along the bottom bar makes contact with an object, the display will read “F:361” (Edge Tripped) and the door will move to the fully open position, with “F:361” displayed, the door will begin to countdown to close. If the reversing edge is impacted three consecutive times the door will remain open until the system is reset.

- To reset the control system with “F:361” displayed, first make sure the area directly below the path of the door is clear of all objects and personnel.
- Then press and hold the reset (●) button until the control reads automatic.
- Press the door close (▼) button to move the door to fully closed position.

### System Reset – Photo Eyes

If either set of photo eyes detects that an object has entered the door opening while the door is closing, the door will reverse direction and move to the fully open position. The door will remain parked in this position until the object has been removed from within the opening. If the front set of photo eyes detects the interruption, the display will read “Photoeye – Fr”. If the rear set of eyes detects the interruption, the display will read “Photoeye – Rr”.

After the door is closed, the display will res “Spiral Door” and the control system will wait for operator input.

### Automatic Door Close Timer

See “Setting Automatic Delay Timers” in the “System 4 Drive & control” manual.

## FINAL ADJUSTMENTS – LEVELING DOOR PANEL

### FINAL ADJUSTMENTS

#### LEVELING DOOR PANEL

1. To check a door panel for level, first position the panel so that it is approximately four or five feet off the floor. Then check the bottom edge of the door panel for level. (The panel is considered level when both sides are within ¼ in. of each other.)

*NOTE: Do not check the door panel for level by visually observing how it rests on the floor. Level is referred off the two side columns and the head assembly.*

2. Before making any adjustment to the door, remove all electrical power to the control panel.



**The disconnect must be in the OFF position and properly locked and tagged before performing the following procedure.**

3. Mounted on the bottom corner of the door is an end bracket (one in each corner). This bracket is clamped around the two ends of the drive belt. (See Figure 86.)

*NOTE: If the door requires adjustment, always lower the high side of the door and never lower the door more than two notches at a time.*

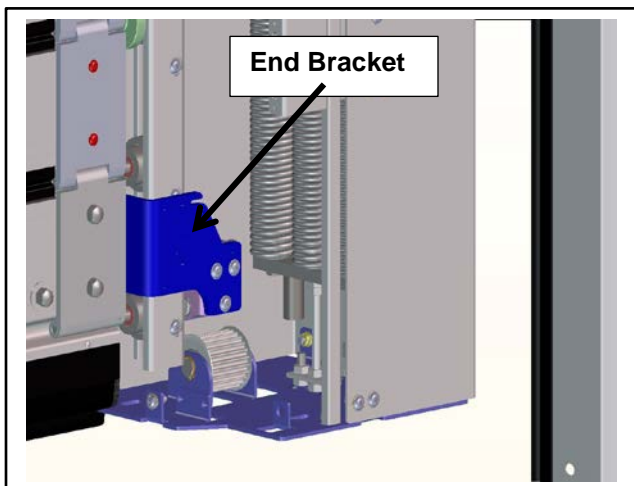


Figure 86

4. Secure the door panels with a rope tied from the end bracket to the drive shaft at the head of the door.
5. Loosen the tension trolley at the top of the side column pushing on the black tooth belt. When the trolley is loose push the trolley away from the wall. This will take tension off the belt. (See Figure 87.)

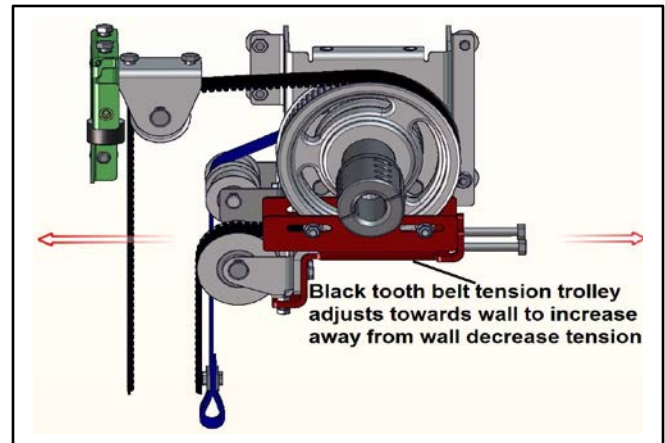
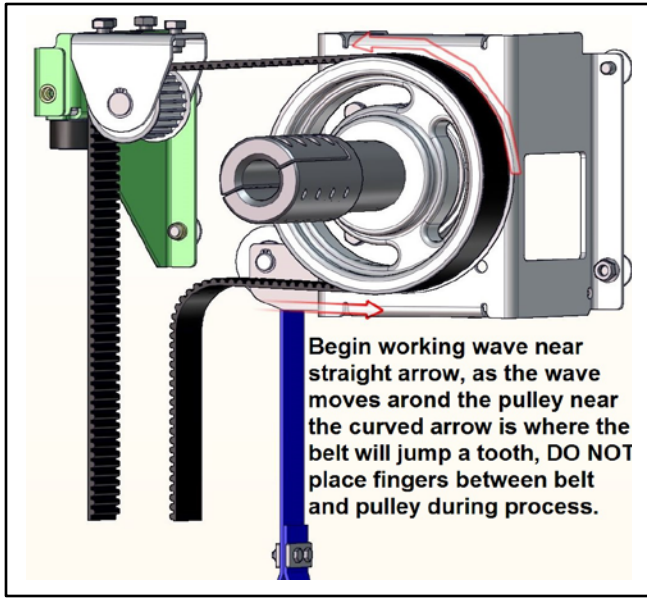


Figure 87



**Before performing the next step be sure the power is turned OFF. The belt is under tension DO NOT place your hand between the belt and the large pulley in the head assembly. Keep your hand on the smooth side of the belt.**

6. Either push on the belt away from the wall toward the large pulley in the console until the belt skips one tooth. Or remove the front plate of the console and access the belt from the front and pull the belt towards you until the belt skips a tooth. As you move the belt towards the pulley a wave will form and travel around the pulley until a tooth is skipped. Continue one tooth at a time until the bottom panel is level. (See Figure 88.)



**Figure 88**

7. Re-apply the tension to the belt with the trolley.
8. Remove the rope from the drive shaft and end bracket.
9. When you confirmed the tension and level panel assembly restore power to the control panel.
10. Cycle the door several times and re-check for level.

## FINAL ADJUSTMENTS – REVERSING EDGE

### TESTING REVERSING EDGE



Take precautions to prevent someone else from operating the door as you perform the following procedure. Also, be cautious around the moving parts that are exposed in the side columns.

With the door fully open, press the door close (▼) button. As the door begins to close, test the door reversing edge by hitting the bottom (rubber) edge of the door. (See Figure 89.)

The reversing edge sensor is working correctly when the door reverses direction to the fully open position. If the reversing edge is impacted three consecutive times the door will remain open until the system is reset.



Figure 89

1. To reset the control system with "F:361 EDGE TRIPPED" displayed, first make sure the area directly below the path of the door is clear of all objects and personnel.
2. Then press and hold the Reset (●) button until the control reads automatic.
3. Press the door close (▼) button to move the door to the fully closed position.

*NOTE: Avoid tripping the photo eye sensors when testing the reversing edge.*

### TESTING PHOTO EYES

#### Front Set Of Eyes

The two modules that make up the front set of photo eyes each have one indicator light. The eyes are receiving power and are aligned when the indicator on the emitter module (right-front eye) is green and the indicator on the receiver module (left-front eye) is red. If both indicators are green, the eyes are not aligned.

When the eyes are aligned and the beam of light between them is interrupted, the receiver module indicator will switch from red to green. Restoring the beam of light will cause the indicator to switch back to red.

#### Rear Set of Eyes

The rear set of eyes when powered up, the emitter (SMT) has a green light, the receiver (SMR) has a yellow when in alignment. When the beam is interrupted, the alignment indicator will go out. Restoring the beam relights the indicator. (See Figure 90.)

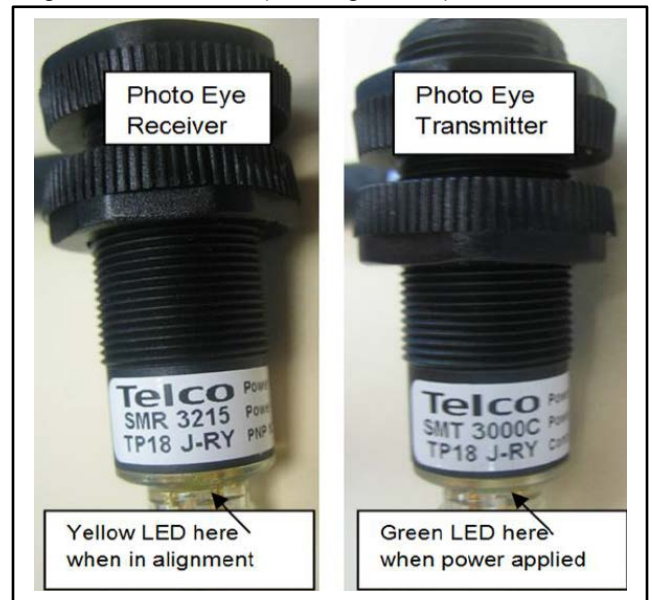


Figure 90



### TESTING PHOTO EYE SYSTEM

#### **⚠ WARNING**

To prevent injury to personnel and damage to equipment, the photo eye circuit must be thoroughly tested to make sure the photo eye system is operating correctly.

1. With power applied to the control panel and the door in the fully-open position, press the door close (▼) button to activate the door.
2. When the door is about halfway closed, break the beam of light between the front set of eyes only.

The moment the beam of light is interrupted, the control panel should reverse the direction of the door and park it in the fully-open position. When the beam of light is restored, the door should automatically move to the closed position.

*NOTE: When the front beam of light is interrupted, the display on the control panel will read "Photo Eye – Fr". When the rear beam of light is interrupted, the display will read "Photo Eye – Rr".*

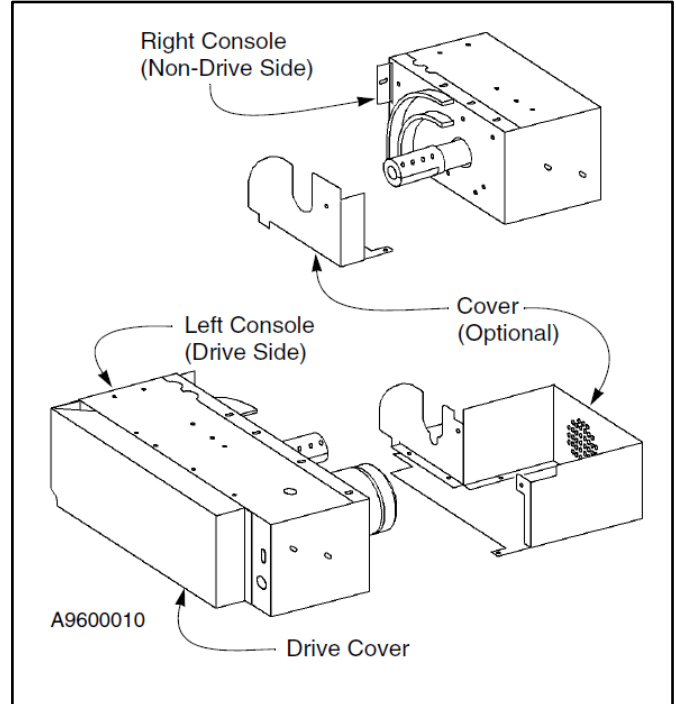
3. Repeat the above procedure on the rear set of photo eyes.

### INSTALLING COVERS

#### **⚠ WARNING**

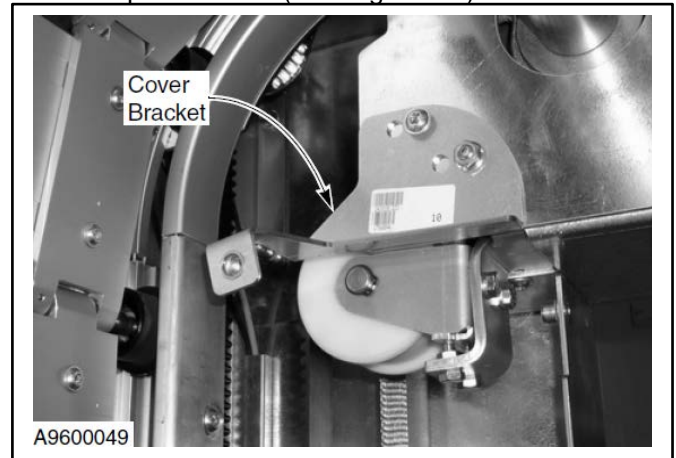
The disconnect must be in the OFF position and properly locked and tagged before performing the following procedure.

1. Check to make sure the side columns and head assembly have remained plumb, square, and level. Also check that all floor and wall anchors have remained securely fastened.
2. Install covers to the console assemblies as required. (See Figure 91.)



**Figure 91**

3. Mount the left and right hand cover brackets to the side columns. These brackets are located in the small parts carton. (See Figure 92.)



**Figure 92**

## FINAL CHECK

4. Attach the left and right hand side covers. (See Figure 93.)

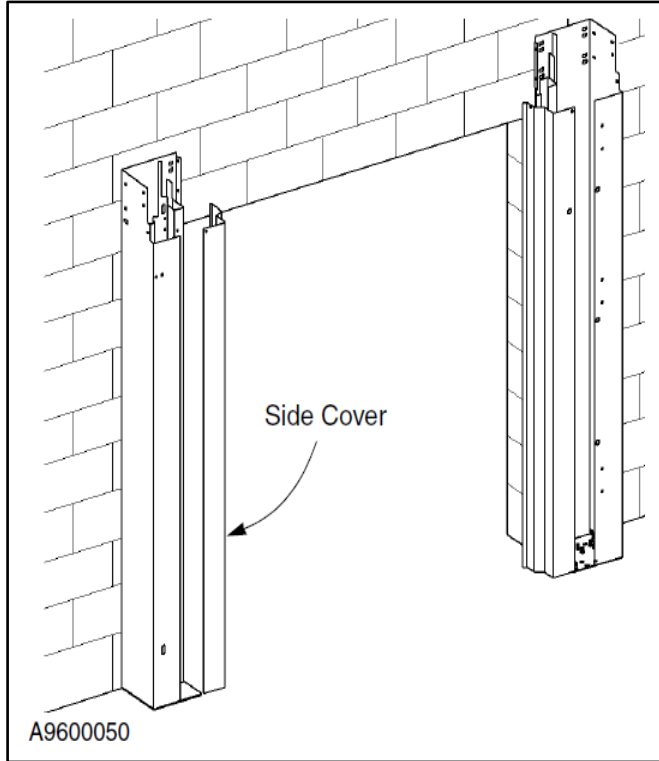


Figure 93

## FINAL CHECK

*NOTE: Check all the following door components and systems once the door panel has been cycled at least 20 times.*

**Side Columns:** Check that side columns are plumb and square and that all anchor bolts are secure and tight.

**Head Assembly:** Check that all mounting hardware is in place and tight.

**Door Panel Track:** Check the alignment of each door track, particularly where the tracks join up between the side columns and head assembly.

**Covers and Panels:** Check that all covers and panels are in place and securely fastened.

**Motor:** Check that the door travels in the proper direction when the button is pressed.

**Reversing Edge:** Check that it works properly. As the door is closing, if the reversing edge makes contact with an object, the door should return to the fully open position as described in "TESTING REVERSING EDGE" on page 42.

**Photo Eyes:** Check that they work properly. As the door is closing, if the light beam between either set of photo eyes is interrupted, the door should return to the fully open position as described in "TESTING PHOTO EYE SYSTEM" on page 42.

**Spring Packs:** Check that all spring packs are securely fastened to the bottom plate of the side column. Also make sure that each nylon spring strap is securely fastened to the clevis bracket at the top of the spring pack.

**Nylon Spring Straps:** Make sure each spring strap is securely fastened to the drive shaft, not twisted and running true to its respective spring pack.

**Drive Belts:** Check that each drive belt is properly tensioned and that the ends of each belt are securely clamped to the bracket assembly. Ensure that the pulley assembly is level and that the belt runs true.

**Drive Belt Pulleys:** Make sure each pulley bracket is properly secured to the base plate of the side column.

**Timers:** Automatic timers must be set to ensure that the door closes properly as described in the System 4 Drive & Control manual.



**Activators:** Check that they operate as specified by the manufacturer.

**Caulk:** Ensure that the side columns and head assembly are caulked where they meet the wall of the building.





