

R Y T E C

# WyndStar MT<sup>®</sup>

---

## Installation & Owner's Manual



P.O. Box 403 One Cedar Parkway, Jackson, WI 53037

Phone: 262-677-9046 Fax: 262-677-2058

Rytec Website: [www.rytecdoors.com](http://www.rytecdoors.com) Rytec On line store: [www.rytecparts.com](http://www.rytecparts.com)

Rytec E mail: [helpdesk@rytecdoors.com](mailto:helpdesk@rytecdoors.com), Parts E mail: [Parts@rytecdoors.com](mailto:Parts@rytecdoors.com)

[Revision: November 10<sup>th</sup>, 2015, R1650118-0, © Rytec Corporation 2001]

# WYND STAR<sup>®</sup>MT LIMITED WARRANTY

Rytec Corporation ("Seller"), an Illinois corporation with its principal place of business at One Cedar Parkway, PO Box 403, Jackson, WI 53037, warrants to the original registered end-user commercial purchaser ("Buyer") that the **Wynd Star<sup>®</sup>MT** ("Product") sold to the Buyer will be free of defects in materials and workmanship (ordinary wear and tear excepted) for the time periods set forth below:

- **Mechanical** components for a period of **One (1) Year** from the date of shipment of the Product from the Seller's plant ("Shipment").
- **Electrical** components for a period of **One (1) Year** from Shipment.
- Standard door panels, including **Vinyl**, for a period of **One (1) Year** from Shipment.
- **Side column brush/vinyl seals, side column self-repair guides, side column wear strip, vinyl loop seal, vision panel sections** are considered wear items and are not covered under this Limited Warranty.
- **Aftermarket parts, accessories, and assemblies** for a period of **Ninety (90) Days** from the date of Shipment.

**Remedies.** Seller's obligation under this Limited Warranty is limited to repairing or replacing, at Seller's option, any part which is determined by Seller to be defective during the applicable warranty period. Such repair or replacement shall be the Seller's sole obligation and the Buyer's exclusive remedy under this Limited Warranty.

**Labor.** Except in the case of aftermarket parts, accessories, and assemblies, labor is warranted for one year. This means that Seller will provide warranty service without charge for labor in the first year of the warranty period. Thereafter, a charge will apply in to any repair or replacement under this Limited Warranty. In the case of aftermarket parts, accessories, and assemblies, Seller will provide replacement parts only.

**Claims.** Claims under this Limited Warranty must be made (i) within 30 (thirty) days after discovery and (ii) prior to expiration of the applicable warranty period. Claims shall be made in writing delivered to the Seller at the address provided in the first paragraph of this warranty. Buyer must allow Seller and Dealer, or their agents, a reasonable opportunity to inspect any Product claimed to be defective and shall, at Seller's option, either (x) grant Seller and Dealer or their agents access to Buyer's premises for the purpose of repairing or replacing the Product or (y) return of the Product to the Seller, f.o.b. Seller's factory.

**Original Buyer.** This Limited Warranty is made to the original Buyer of the Product and is not assignable or transferable. This Limited Warranty shall not be altered or amended except in a written instrument signed by Buyer and Seller.

**Not Warranted.** Seller does not warrant against and is not responsible for, and no implied warranty shall be deemed to cover, damages that result directly or indirectly from: (i) the unauthorized modification or repair of the Product, (ii) damage due to misuse, neglect, accident, failure to provide necessary maintenance, or normal wear and tear of the Product, (iii) failure to follow Seller's instructions for installation, operation or maintenance of the Product, (iv) use of the Product in a manner that is inconsistent with Seller's guidelines or local building codes, (v) movement, settling, distortion, or collapse of the ground, or of improvements to which the Products are affixed, (vi) fire, flood, earthquake, elements of nature or acts of God, riots, civil disorder, war, or any other cause beyond the reasonable control of Seller, (vii) improper handling, storage, abuse, or neglect of the Product by Buyer or by any third party.

**DISCLAIMERS.** THIS WARRANTY IS EXCLUSIVE AND IN LIEU OF ALL OTHER REPRESENTATIONS AND WARRANTIES, EXPRESS OR IMPLIED, AND THE SELLER EXPRESSLY DISCLAIMS AND EXCLUDES ANY IMPLIED WARRANTIES OF MERCHANTABILITY OR FITNESS FOR PURPOSE. SELLER SHALL NOT BE SUBJECT TO ANY OTHER OBLIGATIONS OR LIABILITIES, WHETHER ARISING OUT OF BREACH OF CONTRACT, WARRANTY, TORT (INCLUDING NEGLIGENCE AND STRICT LIABILITY) OR OTHER THEORIES OF LAW, WITH RESPECT TO THE PRODUCTS SOLD OR SERVICES RENDERED BY THE SELLER, OR ANY UNDERTAKINGS, ACTS, OR OMISSIONS RELATING THERETO.

**LIMITATION OF LIABILITY.** IN NO EVENT WILL SELLER BE RESPONSIBLE FOR, OR LIABLE TO ANYONE FOR, SPECIAL, INDIRECT, COLLATERAL, PUNITIVE, INCIDENTAL, OR CONSEQUENTIAL DAMAGES, EVEN IF SELLER HAS BEEN ADVISED OF THE POSSIBILITY OF SUCH DAMAGES. Such excluded damages include, but are not limited to, personal injury, damage to property, loss of goodwill, loss of profits, loss of use, cost of cover with any substitute product, interruption of business, or other similar indirect financial loss.

**Product Descriptions.** Any description of the Products, whether in writing or made orally by the Seller or the Seller's agents, including specifications, samples, models, bulletins, drawings, diagrams, engineering or similar materials used in connection with the Buyer's order, are for the sole purpose of identifying the Product and shall not be construed as an express warranty. Any suggestions by the Seller or the Seller's agents regarding the use, application, or suitability of the Product shall not be construed as an express warranty unless confirmed to be such in writing by the Seller.

**Limited Warranty Void.** This Limited Warranty shall be void in its entirety if:

- a. The Product is modified in a manner not approved in writing by Seller; or
- b. Buyer fails to maintain the Product in accordance with instructions contained in the Owner's Manual for the Product.

# TABLE OF CONTENTS

	PAGE
<b>INTRODUCTION</b> .....	1
HOW TO USE MANUAL .....	1
DOOR SERIAL NUMBER .....	1
<b>SAFETY</b> .....	1
MECHANICAL .....	1
ELECTRICAL .....	1
<b>INSTALLATION</b> .....	2
MATERIAL, TOOLS, AND EQUIPMENT .....	2
ADDITIONAL REQUIREMENTS .....	2
Labor and Site Requirements .....	2
Forklift Requirements .....	2
Electrician's Responsibilities .....	2
GENERAL ARRANGEMENT OF DOOR COMPONENTS .....	3
ANCHORING METHODS .....	3
Concrete, Block, or Brick Walls .....	3
Wood, Block, Brick, or Insulated Walls .....	3
LOCATING SIDE COLUMNS .....	4
SIDE COLUMNS AND HEAD ASSEMBLY .....	5
PHOTO EYES .....	9
TOP SEAL .....	10
HOOD .....	11
MANUAL DOOR PANEL MOVEMENT .....	13
DOOR LIMITS .....	14
Setting Limits .....	13
Limit Switch Designations .....	14
Close Timer .....	15

<b>ADJUSTMENT</b> .....	<b>15</b>
<b>PHOTO EYE</b> .....	<b>15</b>
<b>SERVICE ACCESS</b> .....	<b>15</b>
<b>REPLACEMENT PROCEDURES</b> .....	<b>16</b>
<b>BRUSH SEAL(S)</b> .....	<b>16</b>
<b>DOOR PANEL(S)</b> .....	<b>16</b>
<b>Drum Roll Panel</b> .....	<b>16</b>
<b>Door Panel</b> .....	<b>17</b>
<b>MOTOR/GEARBOX</b> .....	<b>18</b>
<b>PLANNED MAINTENANCE</b> .....	<b>20</b>
<b>RECOMMENDED SCHEDULE</b> .....	<b>20</b>
<b>DAILY INSPECTION</b> .....	<b>20</b>
<b>Visual Damage Inspection</b> .....	<b>20</b>
<b>Check Door Operation</b> .....	<b>20</b>
<b>Photo Eye Inspection</b> .....	<b>20</b>
<b>QUARTERLY INSPECTION</b> .....	<b>21</b>
<b>Hardware Inspection</b> .....	<b>21</b>
<b>HEAD ASSEMBLY</b> .....	<b>21</b>
<b>SIDE COLUMN ANCHORS</b> .....	<b>21</b>
<b>Anchor Inspection</b> .....	<b>21</b>
<b>Fabric Inspection</b> .....	<b>22</b>
<b>Bottom Loop Inspection</b> .....	<b>22</b>
<b>Brush Seal Inspection</b> .....	<b>23</b>
<b>Door Limit Inspection</b> .....	<b>23</b>
<b>CLOSE LIMIT</b> .....	<b>23</b>
<b>OPEN LIMIT</b> .....	<b>23</b>
<b>Motor Brake Inspection</b> .....	<b>23</b>
<b>Bottom Bar Inspection</b> .....	<b>23</b>
<b>Activator Inspection</b> .....	<b>24</b>
<b>Electrical Connection Inspection</b> .....	<b>24</b>
<b>Lubrication</b> .....	<b>24</b>

<b>MISCELLANEOUS</b> .....	<b>25</b>
<b>PANEL CLEANING</b> .....	<b>25</b>
<b>PHOTO EYES</b> .....	<b>25</b>
Operation .....	25
<b>FINAL CHECKS</b> .....	<b>25</b>
<b>PARTS LIST</b> .....	<b>26</b>
<b>PARTS ORDERING INFORMATION</b> .....	<b>26</b>
How to Order Parts .....	26
Substitute Parts .....	26
Return of Parts .....	26
<b>RYTEC TECHNICAL KNOWLEDGE CENTER</b> .....	<b>27</b>
<b>MOTOR ASSEMBLY</b> .....	<b>28</b>
<b>SIDE COLUMN ASSEMBLY</b> .....	<b>31</b>
<b>HEAD ASSEMBLY</b> .....	<b>32</b>
HEAD ASSEMBLY TOP SEAL .....	32
HOOD & DRUM ASSEMBLY .....	33
<b>PANEL ASSEMBLY</b> .....	<b>34</b>
<b>PHOTOEYES</b> .....	<b>35</b>
<b>ELECTRICAL SCHEMATICS</b> .....	<b>36</b>
<b>NOTES</b> .....	<b>40</b>

## INTRODUCTION—HOW TO USE MANUAL

### INTRODUCTION

The information contained in this manual will allow you to install your Rytec Wynd Star MT® Door in a manner that will ensure maximum life and trouble-free operation.

Any unauthorized changes to these procedures, or failure to follow the steps as outlined, will automatically void the warranty. Any changes to the working parts, assemblies, or specifications as written, not authorized by Rytec Corporation, will also cancel the warranty. The responsibility for the successful operation and performance of this door lies with the owner.

**DO NOT INSTALL, OPERATE, OR PERFORM MAINTENANCE ON THIS DOOR UNTIL YOU READ AND UNDERSTAND ALL THE INSTRUCTIONS IN THIS MANUAL.**

If you have any questions, contact your Rytec representative or call the Rytec Technical Support Department at 1-800-628-1909. Please provide the serial number of the door when calling your representative or Technical Support. The location of the serial number is on the left side column assembly.

The wiring connections and schematics in this manual are for general information purposes only. The actual schematic for your custom installation is located in the crate when the door is delivered.

### HOW TO USE MANUAL

Throughout this manual, the following key words are used to alert the reader to potentially hazardous situations, or situations where additional information to successfully perform the procedure is presented:

#### **⚠ WARNING**

**WARNING** is used to indicate the potential for personal injury, if the procedure is not performed as described.

#### **⚠ CAUTION**

**CAUTION** is used to indicate the potential for damage to the product or property damage, if the procedure is not followed as described.

**IMPORTANT:** *IMPORTANT* is used to relay information that is **CRITICAL** to the successful completion of the procedure.

**NOTE:** *NOTE* is used to provide additional information to aid in the performance of the procedure or operation of the door, but not necessarily safety related.

### DOOR SERIAL NUMBER

The **DOOR SERIAL NUMBER** is located halfway up the left side column.

**IMPORTANT:** *When installing multiple doors of the same model, verify the serial number in the control panel/motor assembly, side columns, head/hood, and drum assy.*

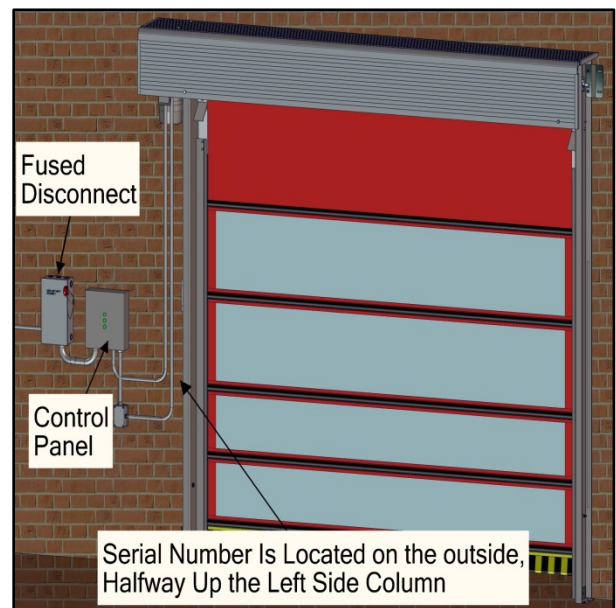


Figure 1

### SAFETY

#### MECHANICAL

- This is a breakaway self-repairable door. Upon impact, the door panel will pop out of the side column guide(s) and automatically reset.
- This is an automatic door. No work of any sort should be done while the power supply is on. Electrical shock can cause serious injury or death.

#### ELECTRICAL

- When working with electrical or electronic controls make sure that the power source has been locked out and tagged according to OSHA regulations and approved local electrical codes.
- Qualified electricians must do all electrical wiring. Wiring must meet all local, state, and federal codes.

## INSTALLATION—MATERIAL, TOOLS, AND EQUIPMENT

---

- Please check the documentation to what voltage is specified. Confirm power supply to be as required 208V, 230/240V, or 460/480V. Voltage and fuses or breakers should be checked before connecting to the main power supply.

### INSTALLATION

#### MATERIAL, TOOLS, AND EQUIPMENT

1. Threaded rod ( $\frac{3}{8}$ -in. and  $\frac{1}{2}$ -in. diameter) and other various wall anchor hardware and material. Concrete anchor bolts ( $\frac{1}{2}$ -in. diameter). (See “ANCHORING METHODS” on page 3.)

NOTE: *Each side column is anchored to the wall and floor. Anchor points are predetermined from the factory.*

2. Assorted shim stock.
3. Steel fish tape.
4. Double-sided tape (for attaching shims to wall).
5. Carpenter’s level (4-ft. minimum length).
6. Carpenter’s square.
7. Hammer drill.
8. Masonry drill bits (for  $\frac{1}{2}$ -in. and  $\frac{3}{8}$ -in. diameter anchors).
9. Hammer or mallet, and block of wood.
10. Crowbar or pry bar.
11. Assorted hand tools (pliers, tape measure, etc.).
12. Socket end wrench sets.
13. Water level, line level, laser level, or transit.
14. Two ladders (taller than height of door opening).
15. Forklift (see “Forklift Requirements” on page 2).

#### ADDITIONAL REQUIREMENTS

##### Labor and Site Requirements

1. Two installers.
2. An electrician is required for making all electrical connections.
3. Unlimited accessibility to the door opening during the entire installation process. No traffic should be allowed to pass through the opening while the door is being installed.

##### Forklift Requirements

A forklift supplied by the customer, dealer, or installer is mandatory for the safe and proper installation of this door. The forklift should have:

- 2000-pound lift capacity
- minimum height ability — door height plus 12 in.
- side-shift capability (desired)

##### Electrician’s Responsibilities

For complete details on the responsibilities of the electrician, refer to the wiring diagram and manual that were shipped with the control drive.

**IMPORTANT: All entries into the control panel MUST be in the bottom of the control panel to maintain the Nema 4X rating. Holes in the top, side, or front of the panel will void the Nema 4X rating and warranty.**

**IMPORTANT: EXTERNAL 3 & 4 WIRE CONTROLS**  
All external devices must be dry contacts, contain no voltage. Many automated carwash controllers send voltage signals under certain conditions during the carwash cycle. These signals will impact the operation of the door. If using automated controls, the controls MUST be a 4 wire dry contact system. Contact closure to open or close the door.

The 3 wire automated system CANNOT be directly connected to the control box. The 3 wire system will require a relay be installed, to separate the signals. If you’re unsure please contact Rytec Technical Support at 1-800-628-1909, please provide the door serial number when calling Rytec.



## INSTALLATION—GENERAL ARRANGEMENT OF DOOR COMPONENTS

### GENERAL ARRANGEMENT OF DOOR COMPONENTS

Figure 2 shows the location of the major components of the door and the general placement of the associated sub-assemblies for a typical installation.

*NOTE: These illustrations are for informational purposes only. They should not be relied upon solely during the installation of your door and its sub-assemblies.*

**IMPORTANT: The surface of the wall on which the door is to be installed must be free of any obstructions. Also, any existing door framing on the wall should be removed or the side panels will require shimming before installing.**

*NOTE: Figure 2 shows the front of the door. Left and right are determined when viewing the front of the door.*

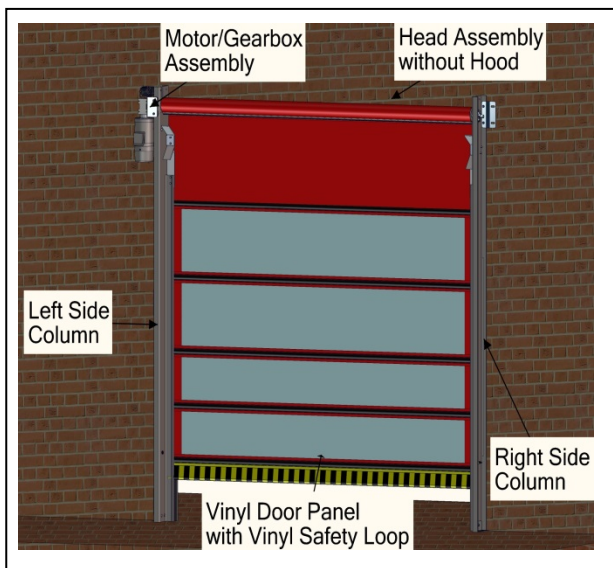


Figure 2

### ANCHORING METHODS

Correct anchoring of the side columns and head assembly to the wall is important for the smooth and safe operation of the door. The wall material should be strong enough to support the weight of the door assembly and all wall anchors.

Figure 3 and Figure 4 show anchoring methods for various types of walls. Use the method that is best suited for your particular installation site.

All necessary anchoring hardware and material required for the installation of this door are the responsibility of the door owner. If you have any questions, call your Rytec representative or the Rytec Technical Support Department at 1-800-628-1909.

*NOTE: Use 1/2-in. diameter threaded through bolts or threaded rods to anchor the door to all wall applications. Use 1/2-in. diameter concrete anchor bolts to anchor the door to a concrete floor. For most applications, 3/8-in. diameter anchors may be used for mounting the jamb to the wall.*

*If expansion anchors are used, a quarterly inspection should be implemented for safe and secure door operation.*

### Concrete, Block, or Brick Walls

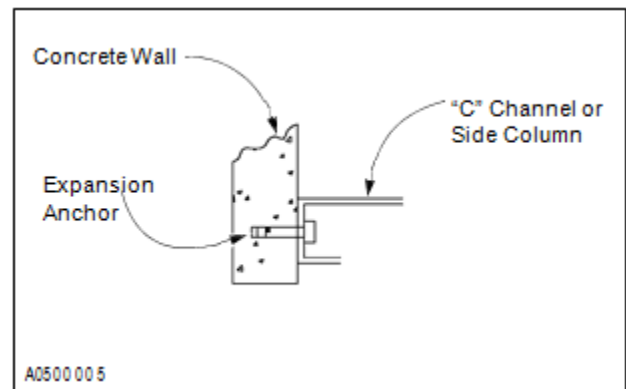


Figure 3

### Wood, Block, Brick, or Insulated Walls

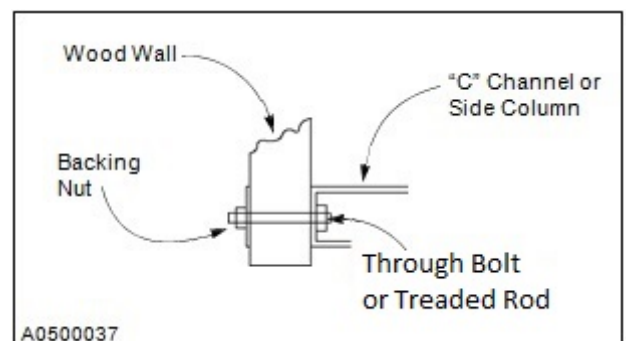


Figure 4

## INSTALLATION—LOCATING SIDE COLUMNS

### LOCATING SIDE COLUMNS

1. Locate the layout drawing of the door. It should be attached to the small parts carton. This drawing identifies the production width of your door.
2. Using the centerline as a reference point, lay out and mark half of the door's production width along the floor. (See Figure 5)

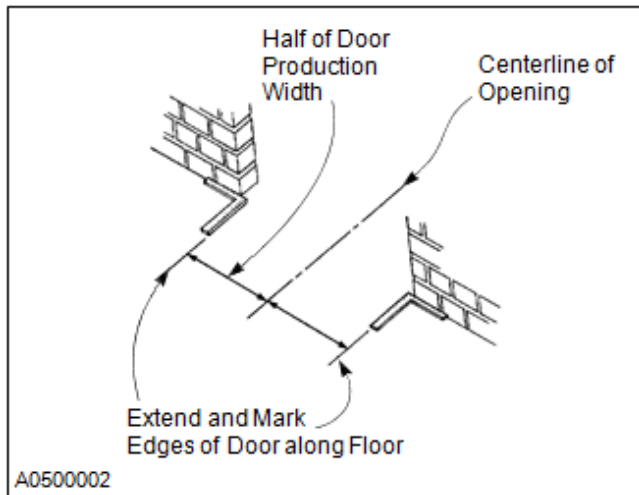


Figure 5

3. With a carpenter's square placed against the wall, mark both sides of the door along the floor. Extend the line along each edge.
4. Check that the floor is level across the door opening. The floor must be level within 0.12 in. (3 mm) from side to side. If one side of the opening is higher than the other, a shim under the side column will be required.

Figure 6 and Figure 7 show two recommended methods that can be used to ensure a level side column installation.

**NOTE:** Contact the Rytec Technical Support Department if the floor is more than 1 in. out of level.

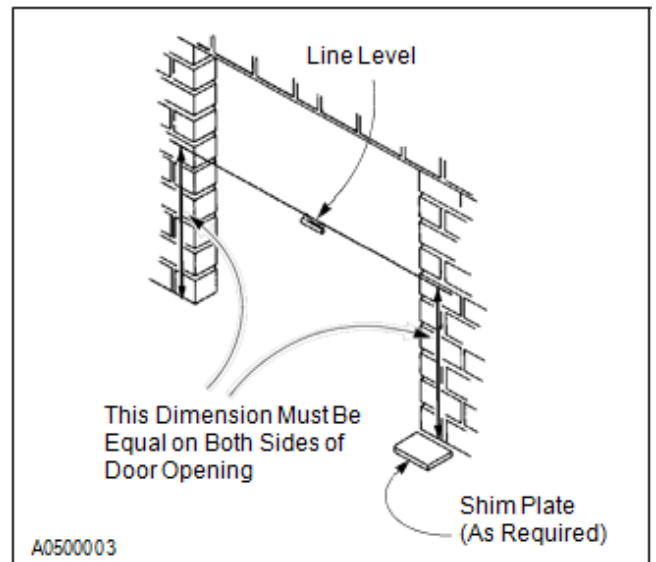


Figure 6

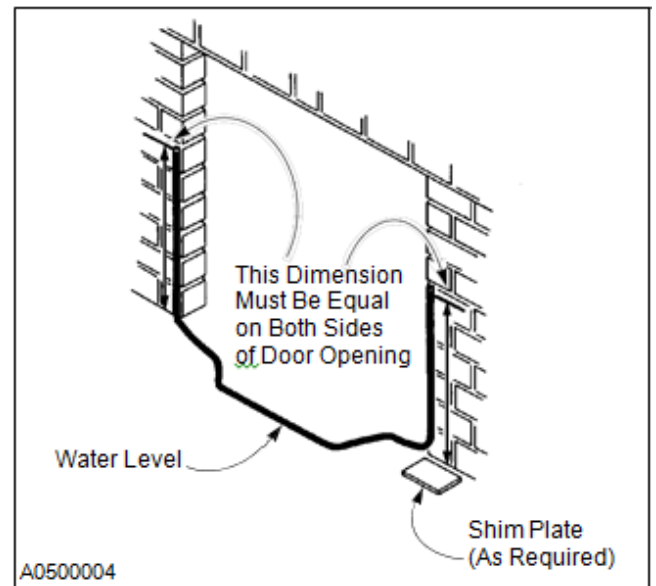
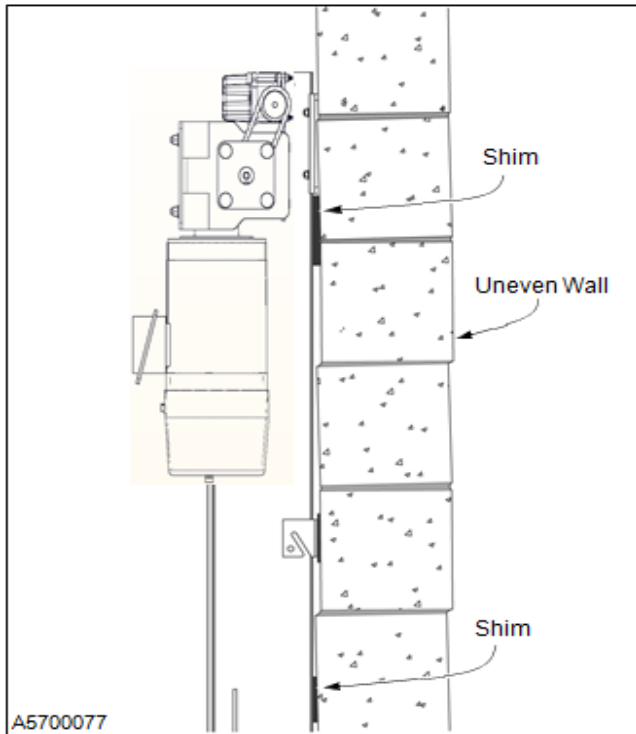


Figure 7

5. Use a plumb bob or carpenter's level to check the wall for plumb in the areas where the wall side columns are to be mounted. Also, inspect the wall for any obstructions.

If the wall is not plumb, use shims. If you find an obstruction, remove it or shim the column to avoid the obstruction. (See Figure 8)



**Figure 8**

**NOTE:** If the door requires more than 1/2 in. to shim around the wall obstruction, longer anchors will be required.

### SIDE COLUMNS AND HEAD ASSEMBLY

The side column is manufactured at the factory to ease the installation of the anchor points, photo eyes, and routing of the wires and cables.

1. Remove the right side column from the shipping crate.

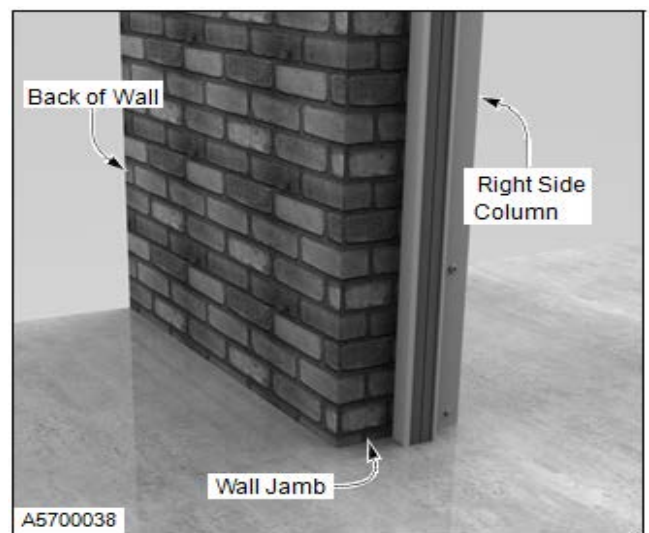
**IMPORTANT:** It is critical that the side columns are mounted square and plumb with the wall, and level across the door opening. Using a 4-ft. level and carpenter's square will help ensure the columns are correctly set. Place shims where necessary.

*In addition, the use of bar clamps will allow you to temporarily secure the columns to the wall, while allowing you to make slight adjustments during the installation process.*

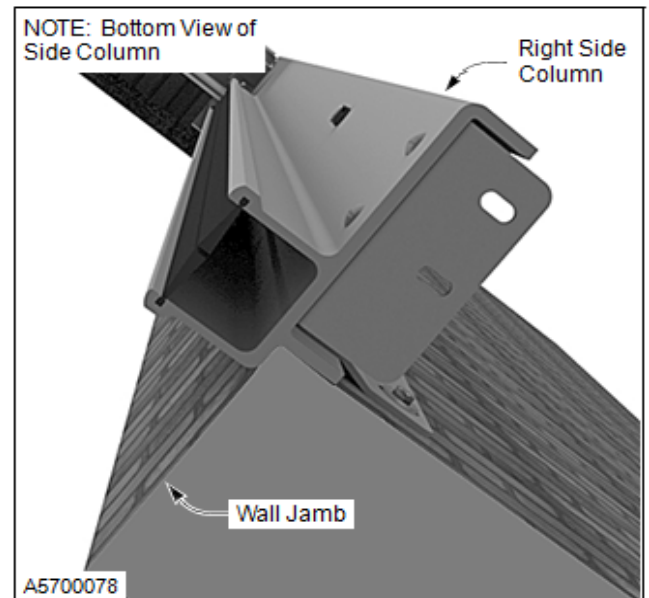
## **⚠ WARNING**

Before drilling any holes, ensure there are no electrical wires, water pipes, gas lines, etc., buried in the floor or hidden in the wall.

2. Stand the right side column on the floor. Place it against the wall and align it flush with the wall jamb.
3. Once the side column is set plumb and square, bar clamp it to the wall. (See Figure 9 and Figure 10)



**Figure 9**



**Figure 10**

## INSTALLATION—SIDE COLUMNS AND HEAD ASSEMBLY

- Anchor the wall bracket. DO NOT tighten the anchors securely at this time — they will be tightened after the head assembly is installed. (See Figure 11)

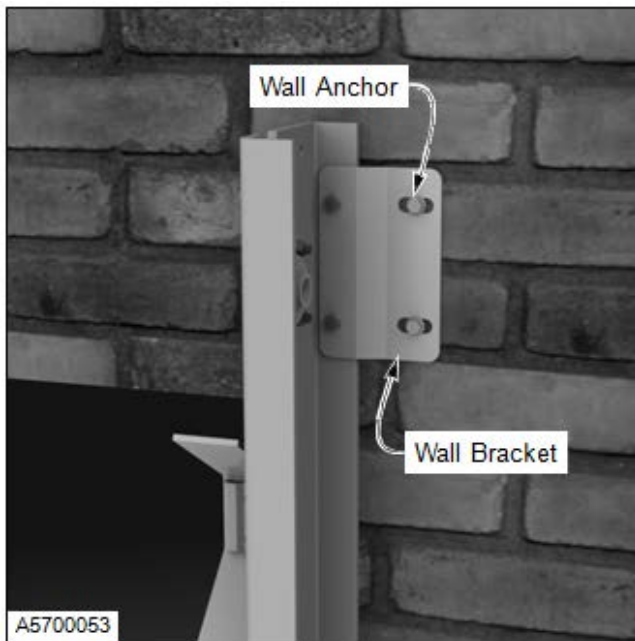


Figure 11

- Anchor the floor angle bracket. DO NOT tighten the anchors securely at this time — they will be tightened after the head assembly is installed. (See Figure 12)

**IMPORTANT:** Use  $\frac{1}{2}$ -in. expansion shell or stud-type anchors for concrete walls. Use through bolts or threaded rods for brick walls and other applications where expansion anchors are not appropriate.

- Secure the drum roll/panel assembly to the forklift or other suitable lifting device.
- Lift and slide the shaft of the drum roll/panel assembly into the bearing block of the right side column. If this is the non-drive side, the distance of the protruding shaft end should be approximately  $1\text{-}\frac{9}{16}$ ". If this is the drive side, the shaft end should protrude  $6\text{-}\frac{1}{16}$ " as measured from the outer most part of the bearing to the shaft end. Loosely tighten the set screw in the bearing bracket to the shaft but the non-drive side location may need to be adjusted later on during the installation. (See Figure 13)
- Slide the locking collar onto the shaft end if this is the non-drive side. Tighten the collar to prevent the drum roll from falling out of the bearing. (See Figure 14)

**NOTE:** Put a coat of anti-seize on the drum shafts to ease the installation and removal of the parts installed on them.

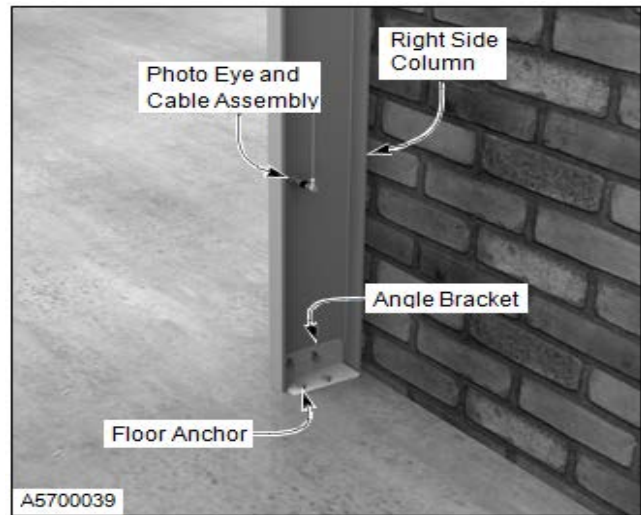


Figure 12

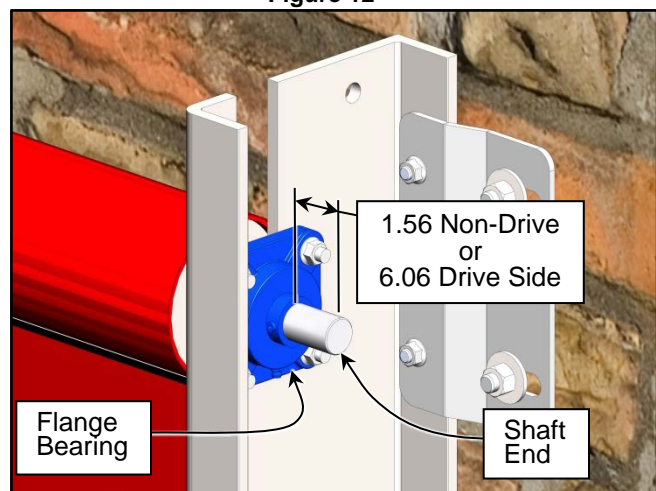


Figure 13

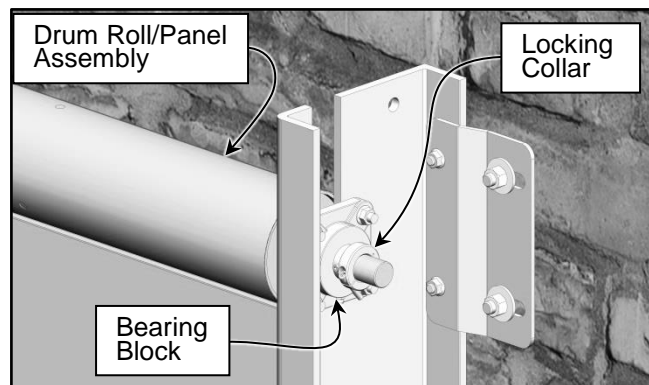


Figure 14

- Stand the left side column up and move it into position by the door jamb. Insert bearing block onto the drum shaft. While inserting bearing block onto shaft end, position against the wall.

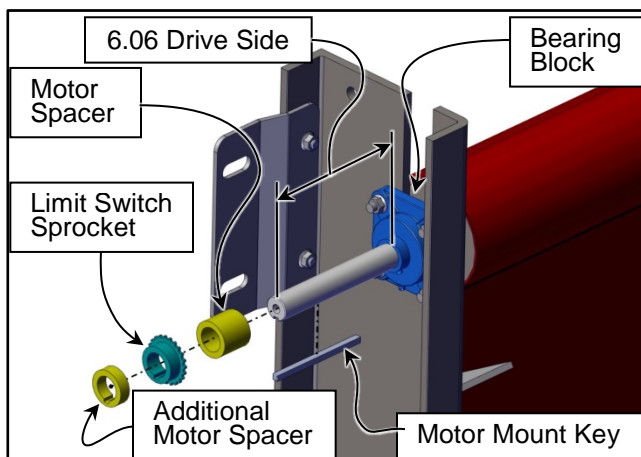
## INSTALLATION—SIDE COLUMNS AND HEAD ASSEMBLY

10. On the non-drive side the distance of the protruding shaft end should be approximately 1-9/16". On the drive side, the shaft end should protrude 6-1/16" as measured from the outer most part of the bearing to the shaft end. Loosely tighten the set screw in the bearing bracket to the shaft. It may need to be adjusted later. Align side column with the wall jamb.
11. Shim and adjust the side column to achieve plumb and square. Once the side column is plumb and square, bar clamp it to the wall.
12. Anchor the wall bracket. **DO NOT** tighten the anchors securely at this time - they will be fully tightened after door assembly is plumb and square.
13. Anchor the floor angle bracket. **DO NOT** tighten the anchors securely at this time - they will be fully tightened after door assembly is square and plumb.
14. When both columns are set, clamped down, and snugly anchored in place, check the overall plumb, square, and parallel of the side columns.

Compare the diagonal measurements and the upper and lower horizontal measurements across the columns. The columns are square and parallel when the diagonal measurements are equal and the horizontal measurements are equal.

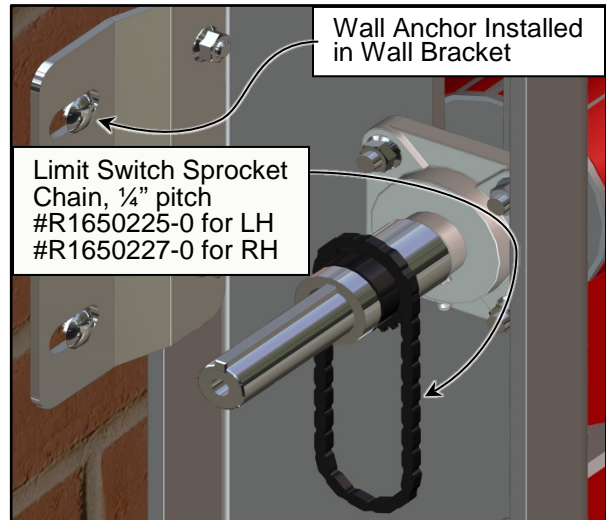
If either column requires slight repositioning (when the difference of either comparison is greater than 1/4 in.), use a block of wood and a mallet to nudge the column into position.

15. Check the position of the Drum/Panel assembly and adjust if necessary.
16. Install the motor spacer onto the drive side of the drum's drive shaft.
17. Install the key into the drive shaft keyway. The key must be flush with the end of the shaft. (See Figures 15 & 16)



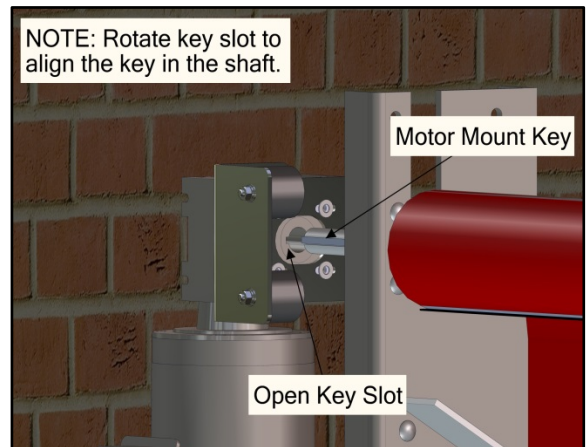
**Figure 15**

*NOTE: Never use a hammer or other hard metallic device to force a key into a keyway.*



**Figure 16**

18. Install limit switch sprocket onto shaft. (See Figure 16)
19. Install additional motor spacer onto shaft. (See Figure 16)
20. Install limit switch drive chain onto the limit sprocket. Chain and master link are located in the small parts carton. Use #R1650225-0 (56 link chain-shorter) for Left Hand Motor Drive units and #R1650227-0 (64 link chain-longer) for Right Hand Motor Drive units (See Figure 16)
21. Align the slot of the motor/gearbox assembly with the key on the shaft. (See Figure 17)
22. Slide the assembly onto the shaft until it butts against the motor spacer. (See Figure 17)

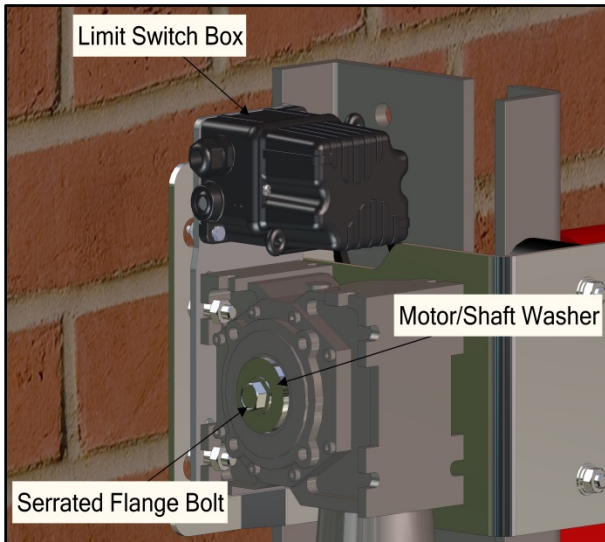


**Figure 17**

## INSTALLATION—SIDE COLUMNS AND HEAD ASSEMBLY

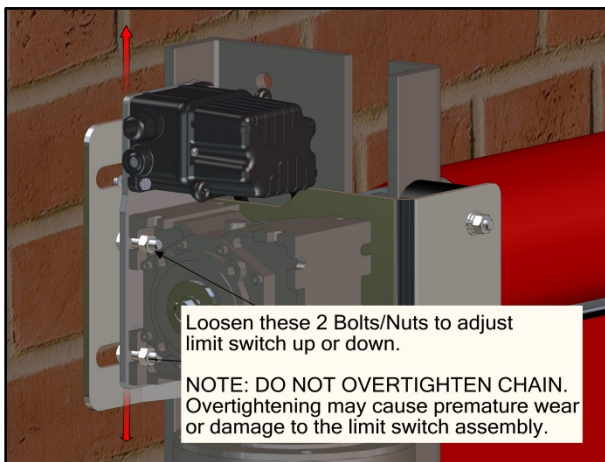
23. Apply a mild thread lock (Loctite) to the serrated flange bolt prior to installation. Install washer and  $\frac{3}{8}$ -16 x 1.5 in. serrated flange bolt to secure the motor assembly (See Figure 18)

*NOTE: The locking collar on the opposite side might have to be loosened in order for the motor/gearbox and door panel assembly to be properly set into position.*



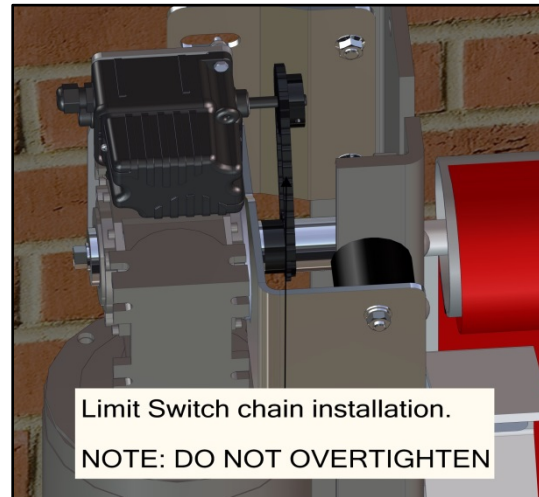
**Figure 18**

24. Tighten the serrated flange bolt to 20 ft-lbs torque.
25. Install the limit switch chain around the two limit sprockets. The plate on the back of the motor can be adjusted up and down to allow for installation. (See Figure 19 & 20)



**Figure 19**

26. The limit switch chain should be lubricated with LPS Brand Force 842 Dry Moly Lube (or equal) once installed and periodically as recommended to insure proper performance.

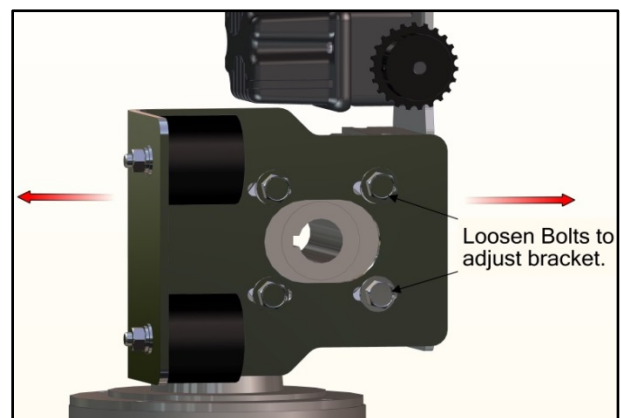


**Figure 20**

27. Recheck the locking collar on the opposite side. Readjust as needed and tighten collar.
28. Using a carpenter's level (4-ft. minimum length), check that the head assembly is level and tighten all hardware and anchors.

### MOTOR ADJUSTMENT

Attached to the motor is a bracket with 2 rubber bumpers. The bracket has 2 rubber bumpers that should fit tightly against the side column when installed properly. The bracket can be adjusted towards or away from the door. Loosen the four hex head bolts and push the bracket towards the side column. A (C-Clamp) can provide assistance to hold the bracket against the side column while tightening the four hex head bolts. (See Figure 21)



**Figure 21**

**PHOTO EYES**

Your door is equipped with two photo eyes mounted on the front of the door. The purpose of these photo eyes is to hold the door open or, if the door is closing, reverse the door to the open position if a vehicle, person, or any object is in the path of the photo eye beam.

The photo eye is not active when the door is closed. After the obstruction breaking the photo eye beam is removed:

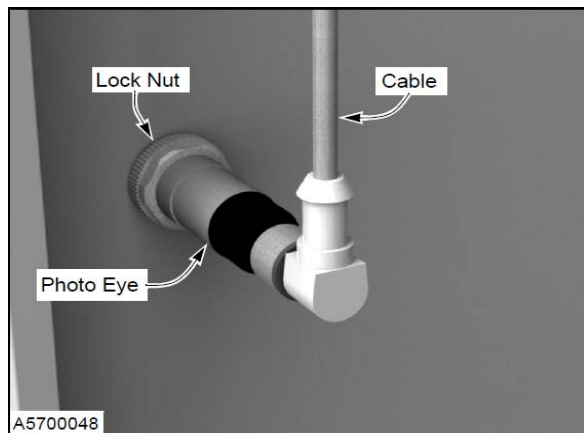
- The door will remain open if it was originally opened by a non-automatic activator until it is closed by a non-automatic activator.
- The door will close automatically if it was originally opened with an automatic activator.

*NOTE: The photo eyes are not intended to be used as a door activator and will not open the door when it is closed.*

This system consists of one pair of non-adjustable emitter and receiver modules. There are no gain or sensitivity settings.

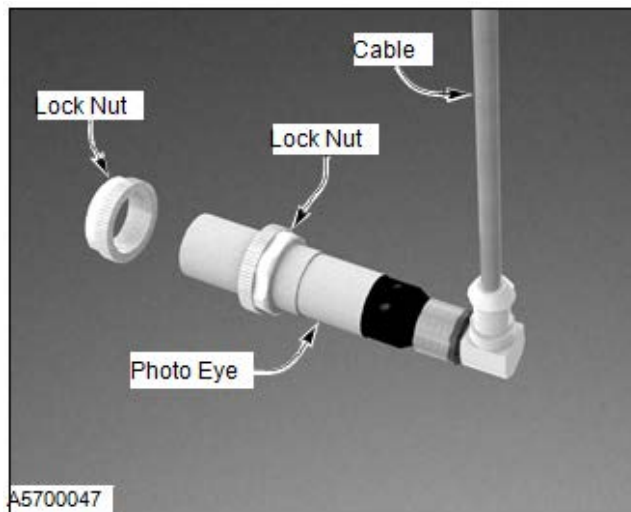
1. Thread the first lock nut onto the shaft of the photo eye.
2. Connect the photo eye cable.
3. Insert photo eye into the side column. (See Figure 22)

*NOTE: Approximate height of photo eyes is 22 in. from floor.*



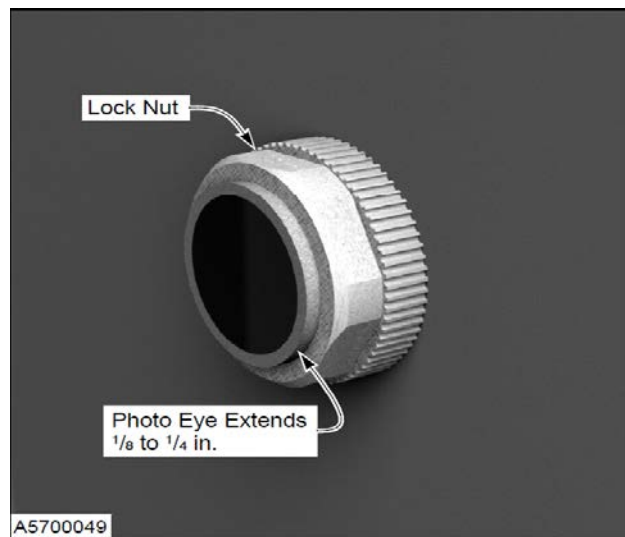
**Figure 22**

4. Thread the last lock nut onto the front photo eye. (See Figure 23)



**Figure 23**

5. Adjust the lock nuts so that the photo eye protrudes 1/8 to 1/4 inch from the end of the assembly. (See Figure 24)



**Figure 24**

6. Connect and route the short cable up the side column to the control board.
7. Connect and route the longer cable up the side column and across the head assembly to the control board.
8. Make sure that the cables are not interfering with any moving parts. Apply plastic ties as required.

## INSTALLATION—TOP SEAL

### TOP SEAL

The top seal for the Rytec Wynd Star MT door.

## **! WARNING**

The disconnect must be in the OFF position and properly locked and tagged before performing the following procedure.

1. Install top hood bracket with two  $\frac{3}{8}$ -16 x 1.25 flat head square neck bolts,  $\frac{3}{8}$ -in. flat washers and  $\frac{3}{8}$ -in. hex serrated flange lock nuts. (See Figure 25)

*NOTE: Back side of door is shown without the wall.*

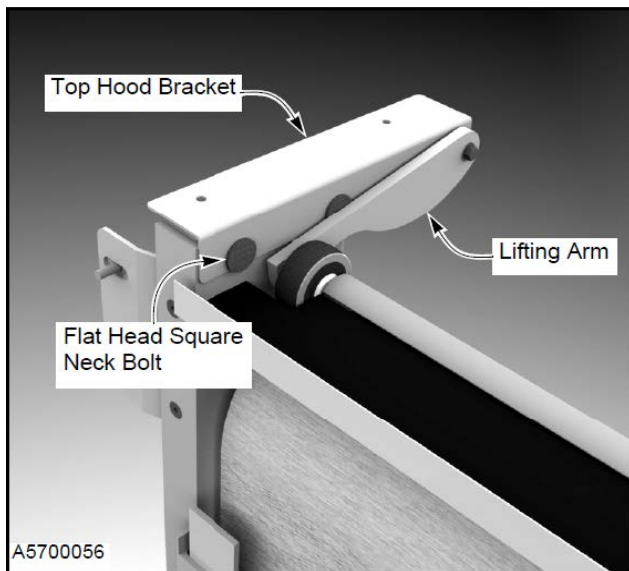


Figure 25

2. Install the top seal assembly to the top hood brackets using a  $\frac{3}{8}$ -16 x 1.50 hex head cap screw, five  $\frac{3}{8}$ -in. washers, and a  $\frac{3}{8}$ -in. lock nut at each end. Use three of the washers between the top hood bracket and lifting arm and one under each piece of hardware. (See Figure 26)

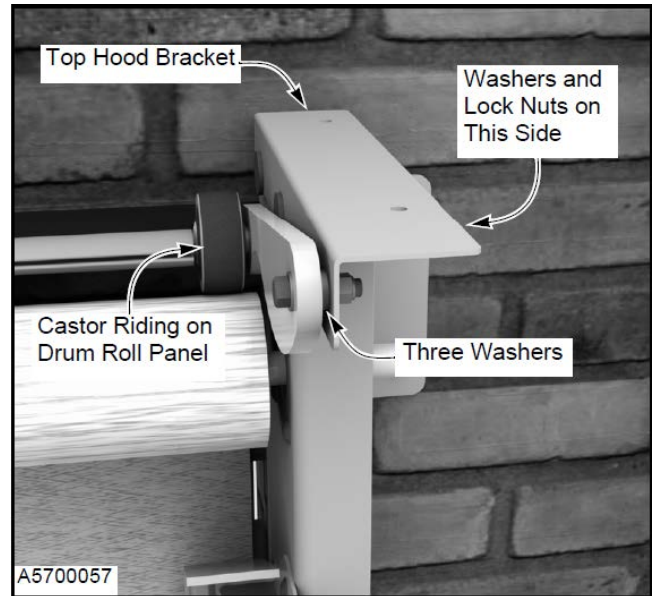


Figure 26

3. With the door panel in the fully-open, position top seal assembly as needed.
4. Mount track to wall. *NOTE: Hardware is NOT provided choose hardware appropriate for your installation.* (See Figure 27)

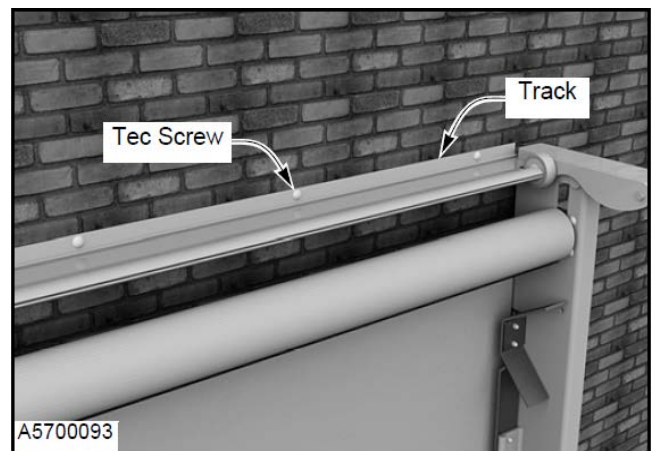


Figure 27

5. Restore power to the door and perform an operations check.



## HOOD

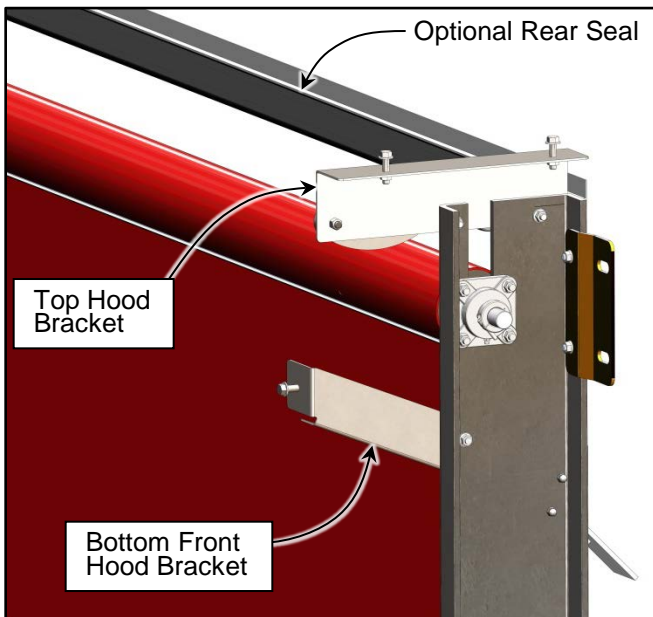
The hood for the Rytec Wynd Star MT door.

*NOTE: If the top seal assembly is already installed, use the pre-existing brackets. If there is no top seal assembly, then the following brackets will have to be installed.*

### **WARNING**

**The disconnect must be in the OFF position and properly locked and tagged before performing the following procedure.**

1. Install top hood bracket with two  $\frac{3}{8}$ -16 x 1.25 flat head square neck bolts, flat washers and hex serrated flange lock nuts.
2. Install bottom hood bracket with a  $\frac{3}{8}$ -16 x 1 round head square neck machine screw, washer and hex serrated flange lock nut. (See Figure 28)



**Figure 28**

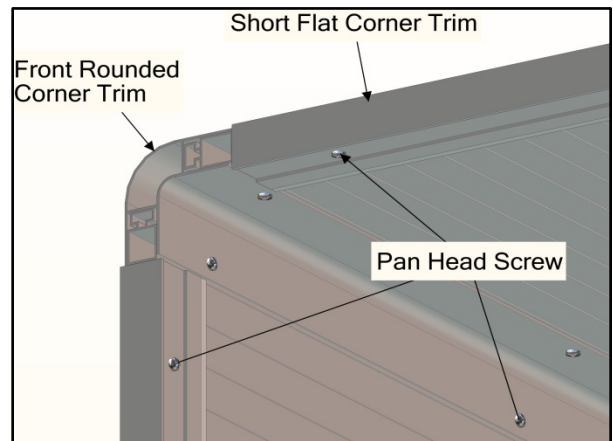
3. Install the short and long rounded corner trims on motor cover side panel. Use #8 x  $\frac{5}{8}$ -in pan head screws. (See Figure 29)

*NOTE: Screws can be mounted on either side of the trim. For a cleaner look, screws can be mounted on the inside of the trim.*

4. Install the rounded front corner trim on top panel. Use #8 x  $\frac{5}{8}$ -in pan head screws. (See Figure 29)

*NOTE: This piece should be mounted flush with the flat corner trim.*

*Screws can be mounted on either side of the trim. For a cleaner look, screws can be mounted on the inside of the trim.*

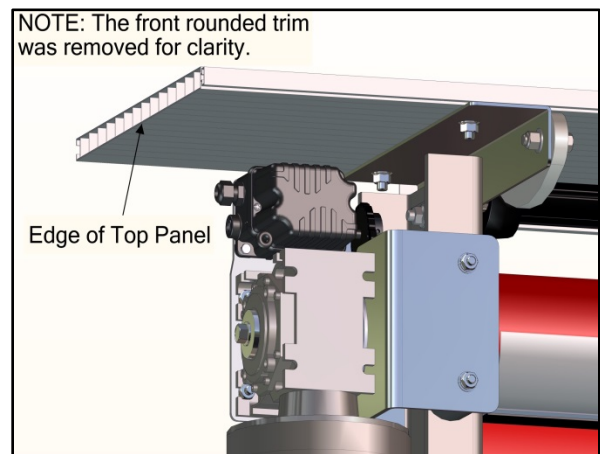


**Figure 29**

5. Install top panel on hood mounting brackets:
  - a. Make sure both ends of the top panel are square and even. Clamp top panel to mounting brackets.
  - b. Mark and lay out hole positions in the top panel.

*NOTE: Mark the hole locations by using the holes on the mounting brackets.*

- c. Remove top panel and drill  $\frac{3}{8}$ -in. holes and deburr. (See Figure 30)



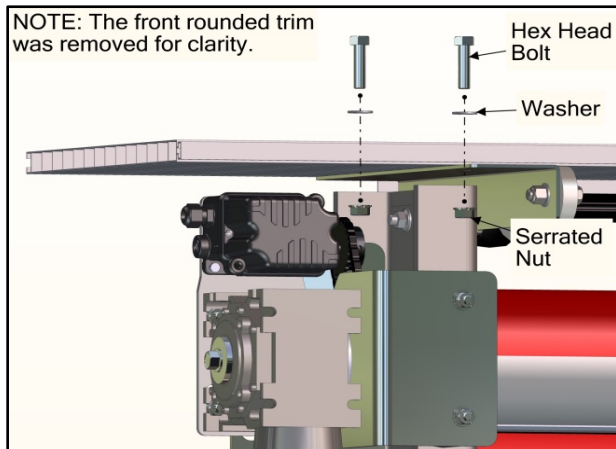
**Figure 30**

## INSTALLATION—HOOD

---

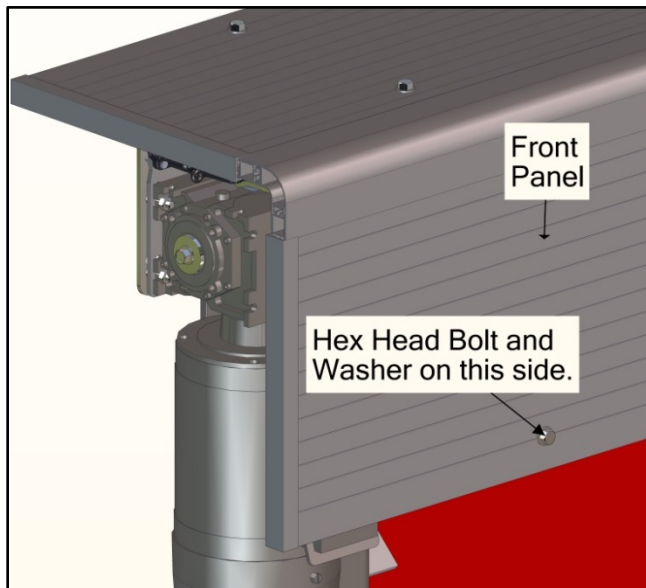
6. Install two  $\frac{3}{8}$ -16 x 1.50 hex head cap bolts, washers, and nuts on both ends of the top panel. (See Figure 31)

*NOTE: Hardware is located in the small parts carton.*



**Figure 31**

7. Install front panel of the hood assembly. Repeat procedure for locating, drilling, and deburring  $\frac{3}{8}$ -in. holes.
8. Install  $\frac{3}{8}$ -16 x 1.50 hex head cap bolts, washers, and nuts on both ends of the front panel. (See Figure 32)



**Figure 32**

## MANUAL DOOR PANEL MOVEMENT

The drive motor has 2 thumb screws at the bottom of the motor. The 2 thumb screws hold the brake cover onto the motor. Remove the 2 thumb screws and brake cover. Removing the brake cover will expose the motor shaft. A socket wrench or impact drive can be used to manually open the door. The door shipped with a 12 point, 15mm socket that can be placed onto the tool to turn the shaft. The manual brake release must be disengaged (1/4 turn clockwise) to manually open the door (See Figure 33). When the door is in the desired position, the manual brake release **MUST** be engaged (reset) to hold the position. Failure to engage the manual brake release will allow the door to move.



Figure 33

Electrical power can be shut off anytime to operate the electric motor in manual mode. Control panel limit settings will not be affected when switching the power off and back on. The door will return to a normal operating mode.

## DOOR LIMITS

Remove the cover to the black rotary limit switch box (2 screws). The S-1 PE Bypass limit switch is used to disable the photoeyes as the bottom edge of the door panel is approximately two inches above the photoeyes. Disabling the photoeyes will reduce false tripping condition caused by the door panel deflecting in a high wind condition.

The photoeye bypass switch is located nearest the wall. The photoeye bypass limit cam has a 60 degree raised area to turn off the photoeyes when the edge is 2 inches above the photoeyes and remain off to the closed position (See Figure 34 & 35)

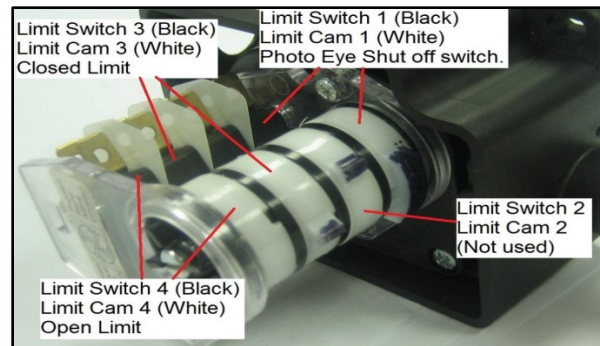


Figure 34

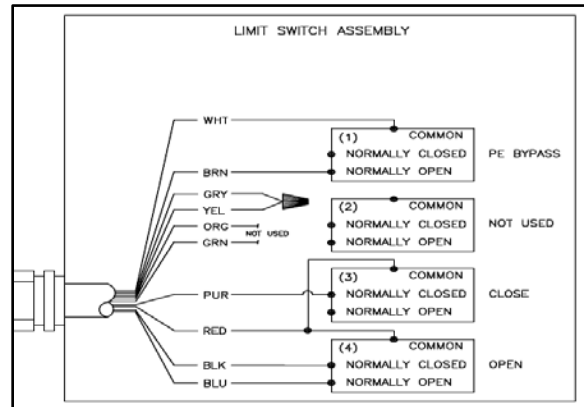


Figure 35

## Setting Limits

The end of the rotary limit switch cams has 5 screws. The larger screw located in the middle is the central screw. This central screw locks the position of each of the white cams after adjustments are completed. The smaller screws are adjustment screws for each individual white cam. Next to each small screw is a number (1-4) indicating which limit cam will be adjusted when the screw is turned. The central screw (large) must be loosened to make adjustments to the individual cam screws (small).

*NOTE: Loosen central screw only 1/4-1/2 turn to allow adjustment screws to turn freely.*

The central cam screw (large) must be tightened before moving the door or the white cam wheels will not turn properly and the adjustment will have to be repeated. (See Figure 36)

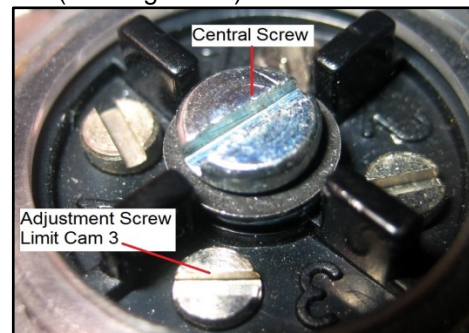


Figure 36

## INSTALLATION – LIMIT SETTING

### **⚠ WARNING**

The disconnect must be in the OFF position and properly locked and tagged before performing the following procedure.

1. Turn power off to the door.
2. Manually adjust the curtain panel until the bottom edge is centered on the outer reinsertion guides. Make note of the direction the white limit cams are turning, this will assist you in making the necessary adjustments required to the particular white cam requiring adjustment (clockwise or counterclockwise). (See Figure 37)

*NOTE: The door panel must unroll from the back (wall side) of the barrel.*

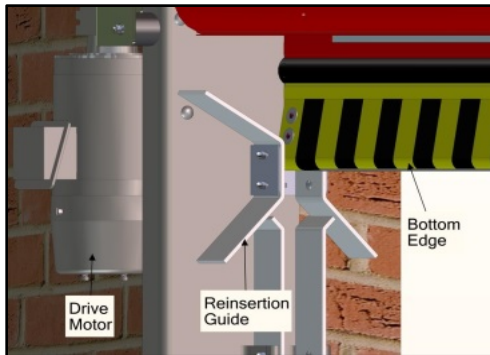


Figure 37

3. Loosen the central screw (large). Turn the adjustment screw for the open limit cam #2 until you hear the #2 limit micro switch click, then tighten the central screw (large) to lock the position.
4. Lower the curtain panel until the bottom edge is 2 inches above the photo eye sensors. (See Figure 38).

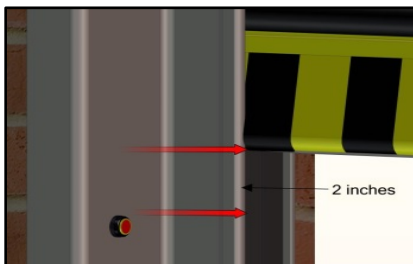


Figure 38

5. Loosen the central screw (large) Turn the adjustment screw for the PE bypass limit cam #1 until you hear the #1 limit micro switch click, then tighten the central screw (large) to lock the position.

*NOTE: The S-1 PE Bypass limit switch is used to disable the photo eyes as the bottom edge of the door panel is approximately two inches above the photo eyes. Disabling the photo eyes will reduce false tripping condition caused by the door panel deflecting in a high wind condition.*

6. Lower the curtain panel until the bottom edge makes light contact with the floor. (See Figure 39)

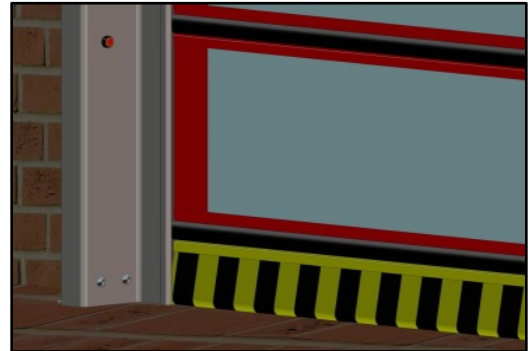


Figure 39

7. Loosen the central screw (large). Turn the adjustment screw for the open limit cam #3 until you hear the #3 limit micro switch click, then tighten the central screw (large) to lock the position.

### Limit Switch Designations

- **S1** – Photo Eye Bypass limit (PE Bypass) nearest to wall.
- **S2** – Not Used
- **S3** – Closed Limit
- **S4** – Open Limit, farthest from wall.

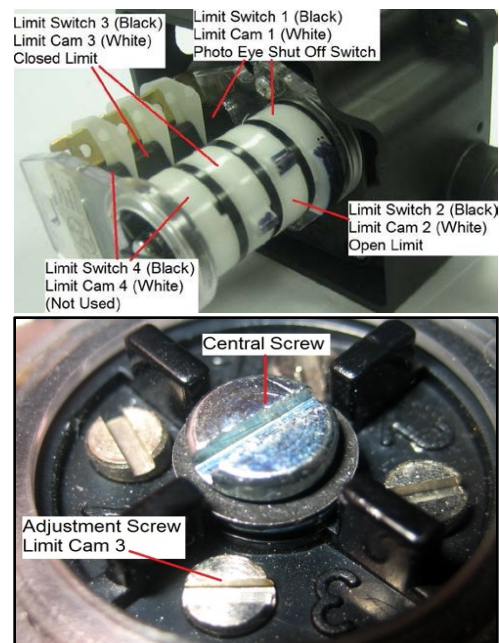


Figure 40

## Close Timer (Optional)

1. The timer function allows the door to close automatically after a predetermined time. (See Figure 41 & 42)

*Note: The close timer (T4) is optional. Part number is R0115000. To place an order contact the Rytec parts department at 1-800-628-1909 or fax parts at 1-262-677-2058.*

2. To eliminate the auto close timer, remove the jumper between terminals 42 and 43 in the control box.

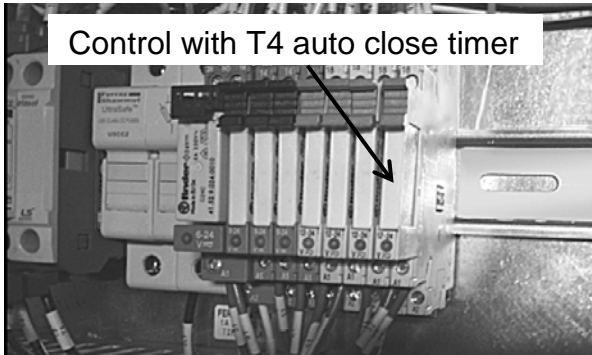


Figure 41

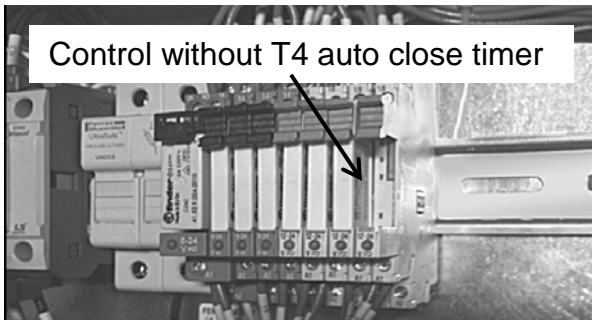


Figure 42

3. To adjust the T4 auto close timer turn the dial on the side clockwise to increase time and counterclockwise to decrease the auto close timer. (See Figure 43)

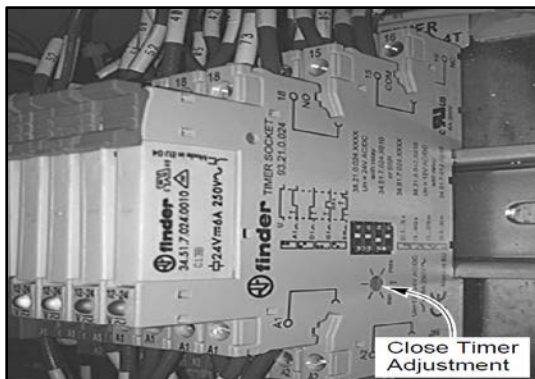


Figure 43

## ADJUSTMENT

### ADJUSTMENT—PHOTO EYE

#### PHOTO EYE

Both the emitter and receiver photo eyes have a green LED (light-emitting diode) built into them. When power is applied to the photo eyes, the green LED light will illuminate indicating that they are working. The receiver also has a yellow LED. Once the photo eyes are in alignment, the yellow light will turn on.

1. Loosen the screws on the emitter socket bracket and adjust the photo eye so that it is square to the mounting bracket assembly or side column. Tighten the screw when this is achieved.
2. Loosen the screw on the receiver socket bracket and adjust the photo eye until the yellow LED illuminates.

*NOTE: The door will not operate until the photo eyes are in alignment.*

### SERVICE ACCESS

Prior to any adjustments, parts removal, or lubrication to the head assembly, the hood may need to be removed.



**The disconnect must be in the OFF position and properly locked and tagged before performing the following procedure.**

1. Remove the six hex head cap screws, washers, and lock nuts from the hood assembly. (See Figure 44)



Figure 44

2. Perform maintenance as needed.
3. Secure the hood by performing the steps in reverse

## REPLACEMENT PROCEDURES—BRUSH SEAL(S)

### REPLACEMENT PROCEDURES

#### BRUSH SEAL(S)



The disconnect must be in the OFF position and properly locked and tagged before performing the following procedure.

1. Remove the two acorn nuts and round head square neck machine screws.
2. Remove the bottom bar guide(s) from the side column. (See Figure 45)

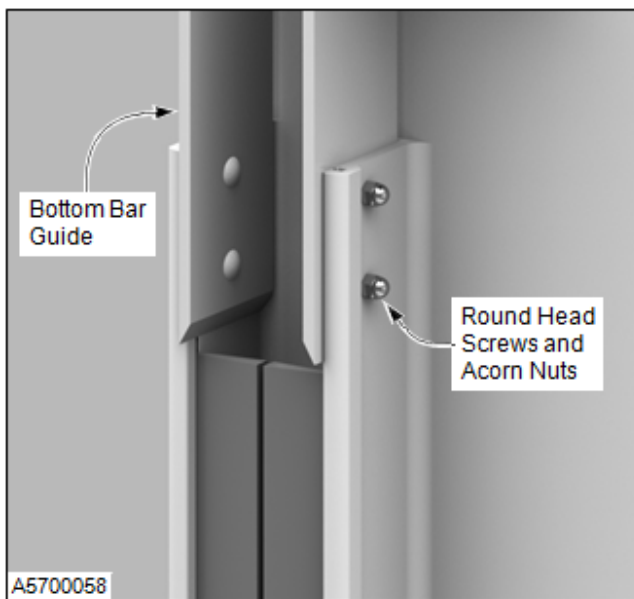


Figure 45

3. Remove the old weather seal by sliding it out of the track.
4. Slide a new brush seal into the track.
5. Install bottom bar guide, round head screws, and acorn nuts.

#### DOOR PANEL(S)



The disconnect must be in the OFF position and properly locked and tagged before performing the following procedure.

The drum roll panel is attached to the drum roll using a clamp bar and rivets. The separate, smaller door panels below are attached to each other with a wind rib and two roll pins, one at each end. (See Figure 46 and Figure 47.) The roll pins are located about 1 in. from the end of the panel.

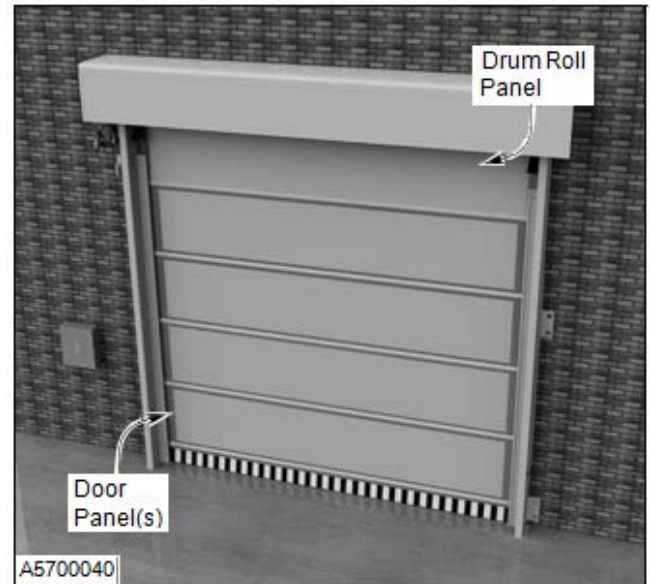


Figure 46

#### Drum Roll Panel

1. Make sure the door is in the closed position and the power turned off.

*NOTE: With the door in the closed position, the clamp bar should be exposed. If not, release the motor brake and manually turn the drum until it can be seen. See "Manual Door Panel Movement" section on page 13.*

2. Remove the top seal (if installed).
3. Pop out the door panel from the side column(s). This will make the repair easier.
4. Remove roll pins from the ends of the wind rib.

*NOTE: The roll pins are located about 1 in. from the end of the panel.*

5. Slide the wind rib out from between the drum roll panel and door panel. (See Figure 47)

## REPLACEMENT PROCEDURES—DOOR PANEL(S)

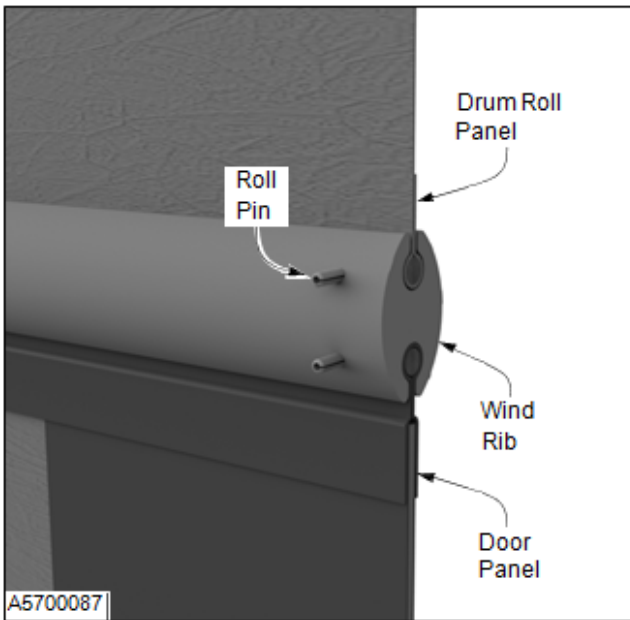


Figure 47

6. Remove the protective strip covering the hardware and clamp bar. (See Figure 48)

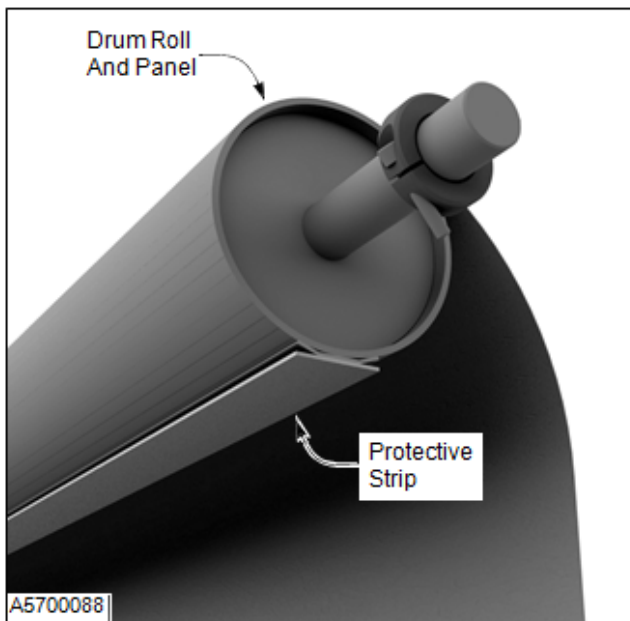


Figure 48

7. Drill out the rivets from the clamp bar and remove the drum roll panel. (See Figure 49)

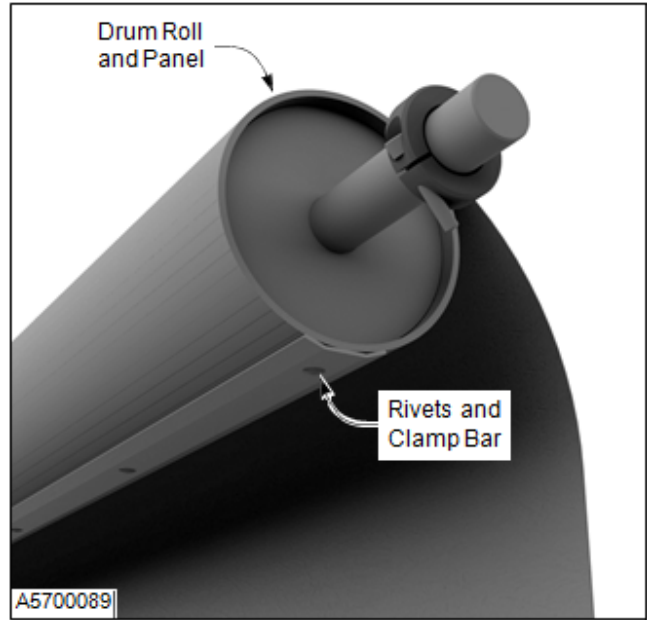


Figure 49

8. Clean the surface of the drum roll and remove any burrs from the rivet holes.
9. Reinstall the drum roll panel by performing the steps in reverse order.

*NOTE: Make sure the drum roll panel is installed straight.*

10. Reinstall the wind rib between the drum roll panel and door panel.
11. Install roll pins into the ends of the wind rib.
12. Restore power to the door.

*NOTE: The door panel will reset itself after the power has been restored.*

13. Perform operations check. Adjust door limits as needed.

### Door Panel

1. Make sure the door is in the closed position and power turned off.
2. Pop out the door panel from the side column(s). This will make the repair easier.
3. Remove roll pins from the end of the wind ribs on the worn door panel.

*NOTE: The roll pins are located about 1 in. from the end of the panel.*

4. Slide either the top or bottom wind rib out of the worn door panel. (See Figure 50)

## REPLACEMENT PROCEDURES—MOTOR/GEARBOX

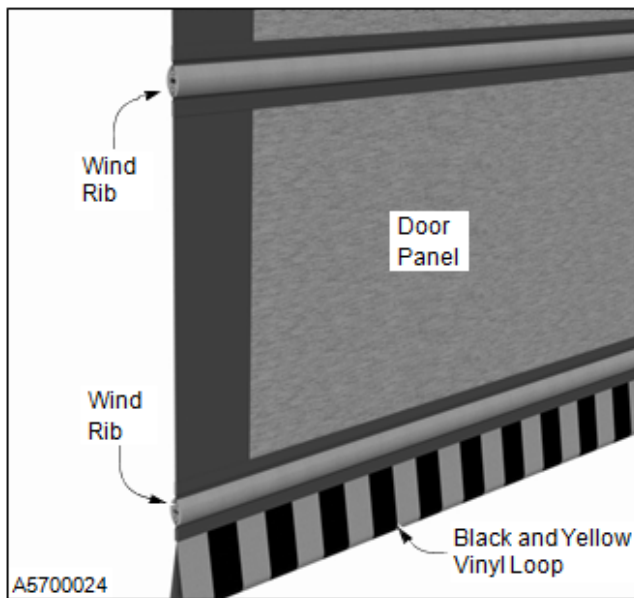


Figure 50

5. Remove the worn door panel from the other wind rib.
6. Reinstall the new door panel by performing the steps in reverse order.
7. Install roll pins into the ends of the wind rib.
8. Restore power to the door.

*NOTE: The door panel will reset itself after the power has been restored*

9. Perform operations check. Adjust door limits as needed.

### MOTOR/GEARBOX



**The disconnect must be in the OFF position and properly locked and tagged before performing the following procedure.**

1. Make sure the door is in the open position.
2. Turn off the power.
3. Tie off the door panel assembly so that it will not unroll when the motor/gearbox is removed.
4. Gain access to the motor/gearbox by removing the hood (if installed). (See "HOOD (OPTIONAL)" on page 34)
5. Remove the top seal assembly. (See "TOP SEAL (OPTIONAL)" on page 32)

*NOTE: Label all connections as required. The wire diagram or schematic that came with the door should be used when re-assembling the connections*



Figure 51

6. Loosen the four cap screws and slide the isolator bracket away from the side column. (See Figure 52)

*NOTE: The view of the motor/gearbox is from the back side*

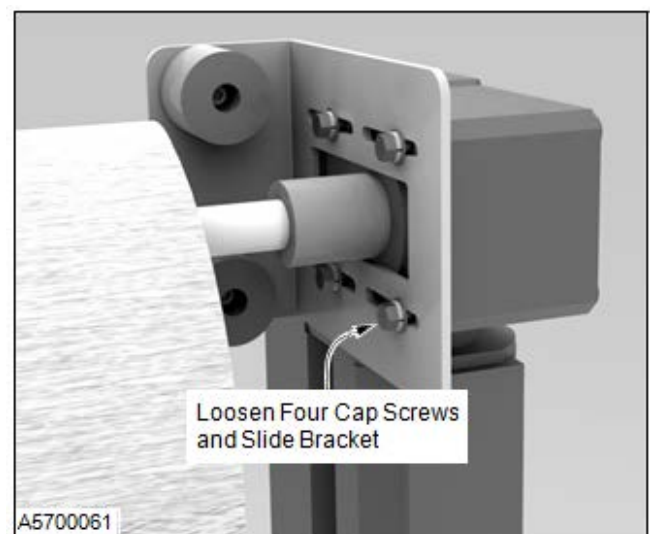


Figure 52

7. Remove serrated flange screw and flat washer from shaft end. (See Figure 53)



## REPLACEMENT PROCEDURES—MOTOR/GEARBOX

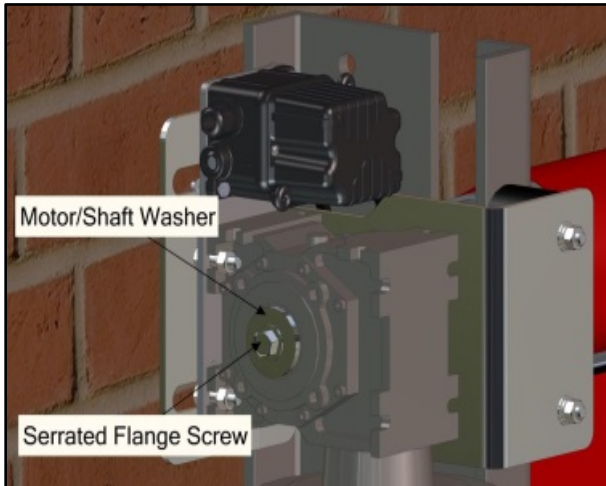


Figure 53

8. Remove motor/gearbox and bracket assembly from shaft.
9. Inspect key slot on the shaft end for wear and tear. Refurbish as needed. (See Figure 54)

*NOTE: If you have any questions, contact your Rytec representative or call the Rytec Technical Support Department at 1-800-628-1909.*



Figure 54

10. Install the key in the slot of the shaft.
11. Remove the isolator bracket from the old motor/gearbox.
12. Install the four cap screws, lock washers, and flat washers through the isolator bracket and into the new motor/gearbox. (See Figure 55)

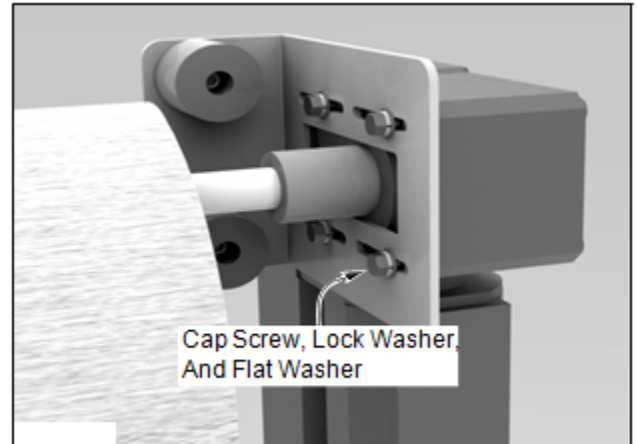


Figure 55

13. Align the keyway and install the motor/gearbox onto the shaft.

*NOTE: Put a coat of anti-seize on the shaft to ease the installation and removal of the motor.*

14. Install serrated flange screw and flat washer onto shaft end. (See Figure 56)

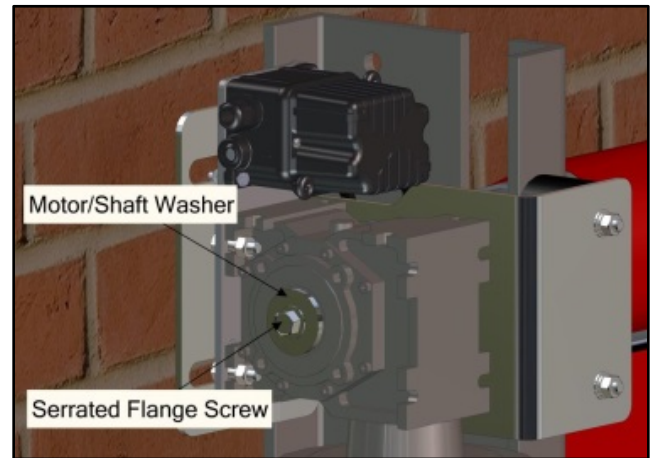


Figure 56

15. The limit switch chain should be checked and lubricated any time it is serviced to insure appropriate coverage after handling.
16. Connect the door operator and electrical connections to the motor/gearbox.
17. Restore power to the door and perform an operations check. Adjust door limits as needed.
18. Install hood and end panel.
19. Return door to service.

## PLANNED MAINTENANCE—RECOMMENDED SCHEDULE

### PLANNED MAINTENANCE

#### RECOMMENDED SCHEDULE

*NOTE: The following maintenance schedule is recommended for the Rytec Cycle-Plus maintenance program.*

	Daily	Quarterly
Visual Damage Inspection		
Check Door Operation		
Photo Eye Inspection		
Hardware Inspection		
Wall Anchor Inspection		
Fabric Inspection		
Weather Seal Inspection		
Close-Limit Inspection		
Open-Limit Inspection		
Motor Brake Inspection		
Bottom Bar Inspection		
Activator and Control Panel Inspection		
Electrical Connection Inspection		
Lubrication		

#### DAILY INSPECTION

##### Visual Damage Inspection

Visually inspect the door to see that components have not been damaged. Example: bent bottom bar assembly, torn fabric panel, damage to side columns, etc. (See Figure 57)

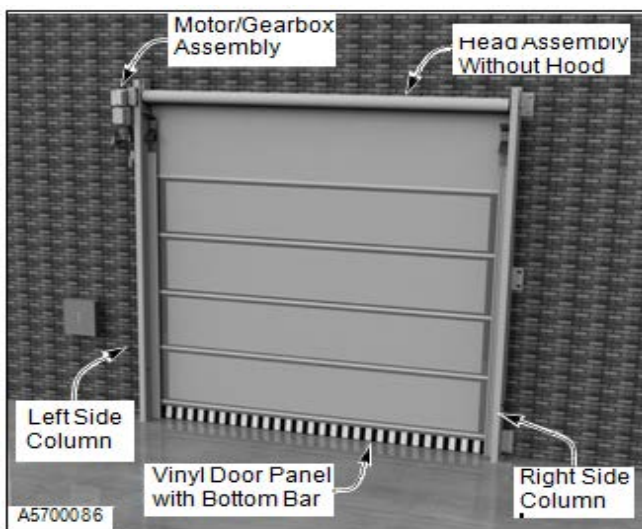


Figure 57

**Head Assembly:** Inspect for dents or damage that may prevent the door from opening or closing properly.

**Door Panel:** Inspect panel for holes, tears, and worn areas. If equipped with windows, inspect them for damage or dirt that may impair vision — clean or replace as required.

**Side Columns:** Inspect for damage that may prevent the door from operating properly.

**Photo Eyes:** Inspect the lens of each photo eye for damage or dirt that may prevent the photo eyes from working properly — clean or replace as required.

**Bottom Bar:** Inspect the bottom bar for damaged, missing, or loose hardware. Inspect the yellow vinyl seal along the lower edge of the bottom bar for tears and holes. Inspect the edge itself.

##### Check Door Operation

Run the door through four or five complete cycles to verify that the door is operating smoothly and efficiently, and that binding or unusual noises do not exist. DO NOT continue to operate the door if it is not running properly, as this could compound the damage.

##### Photo Eye Inspection

*NOTE: Photo eyes act as a safety device to prevent the door from closing if an object or person is within either photo eye beam. The photo eyes are not meant to be used as door activators.*

Once power is applied, green lights on the photo eye emitter and receiver indicate that the modules are powered up. When the yellow light on the receiver module is also lit, the emitter and receiver are properly aligned.

Placing your hand in front of the receiver breaks the light path and causes the yellow light to go out. Removing your hand causes the yellow light to come back on. (See Figure 58)

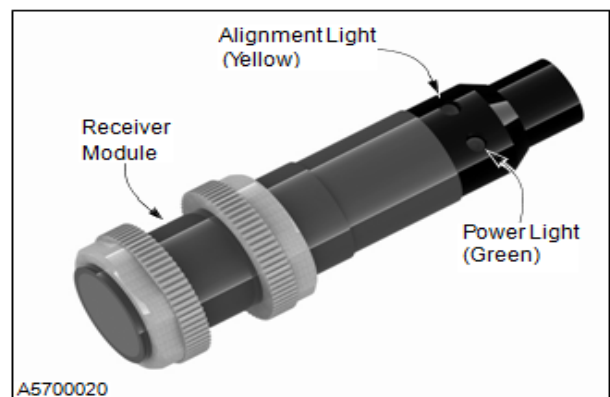


Figure 58

QUARTERLY INSPECTION



The disconnect must be in the OFF position and properly locked and tagged before performing the following procedure.

Hardware Inspection

Make sure all nuts, bolts, set screws, and anchors are tight throughout the door. Example: motor mounting bolts, wall mounting hardware, floor anchors, set screws, etc. (See Figure 59 & 60)

HEAD ASSEMBLY

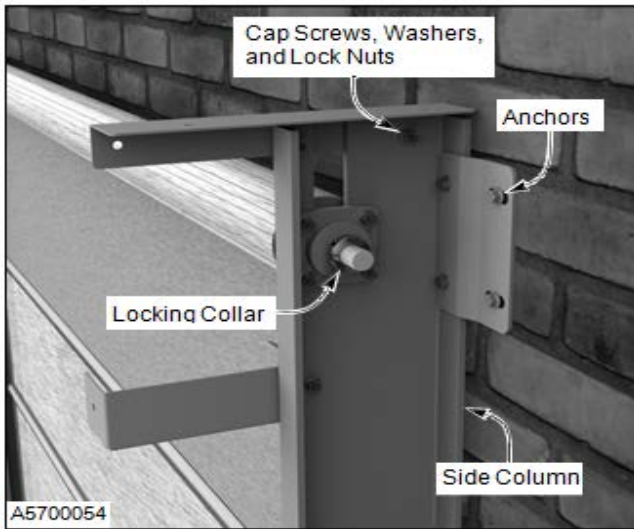


Figure 59

SIDE COLUMN ANCHORS

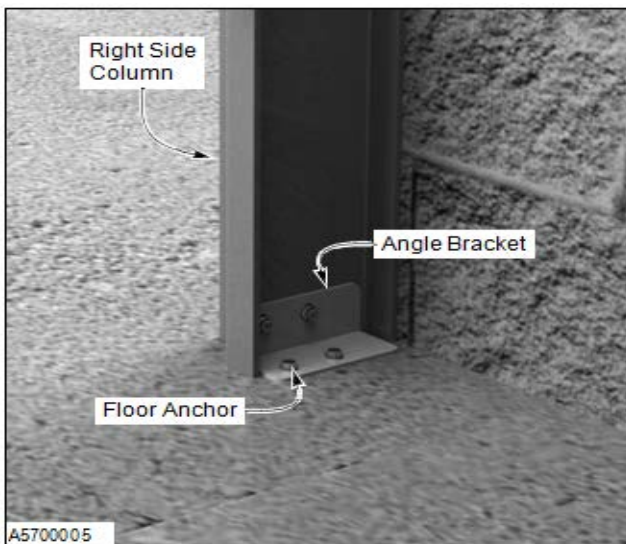


Figure 60

Anchor Inspection

1. Turn off power to the door.



The disconnect must be in the OFF position and properly locked and tagged before performing the following procedure.

2. Gain access to floor and wall anchors.
3. Inspect for loose or worn anchor(s). (See Figure 61)

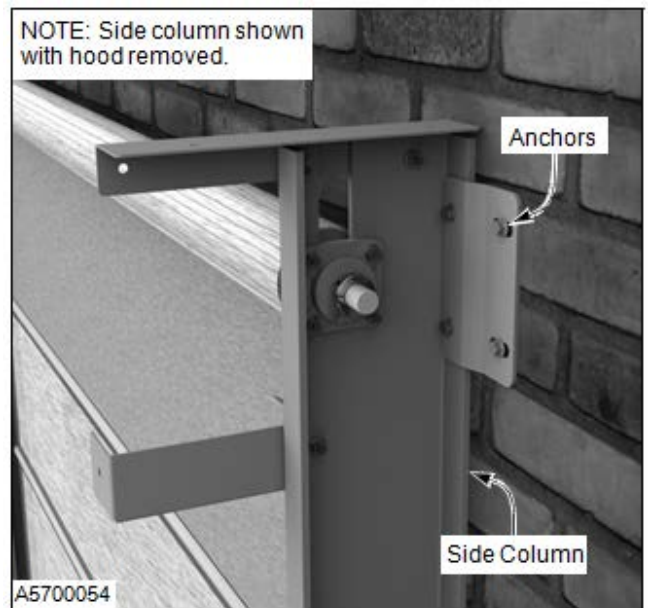


Figure 61

4. Tighten, repair, or replace anchor(s) as needed.

*NOTE: Remove door from service if any repairs are needed. All repairs must be done in accordance with municipal building codes.*

5. Restore power to the door and return to service.

## PLANNED MAINTENANCE—QUARTERLY INSPECTION

### Fabric Inspection

1. Turn off power to the door.



The disconnect must be in the OFF position and properly locked and tagged before performing the following procedure.

2. Check the fabric for holes, tears and worn areas. Repair or replace as required.
3. If your door panel is equipped with windows inspect them for damage or dirt that may impair vision. Clean or replace as required.

**IMPORTANT:** Use any good brand of window cleaner to clean the windows. DO NOT use abrasive cleaners or petroleum-based solvents.

4. Ensure the panel is securely fastened to the bottom bar assembly. Tighten or replace loose or damaged mounting hardware as required. (See Figure 62)

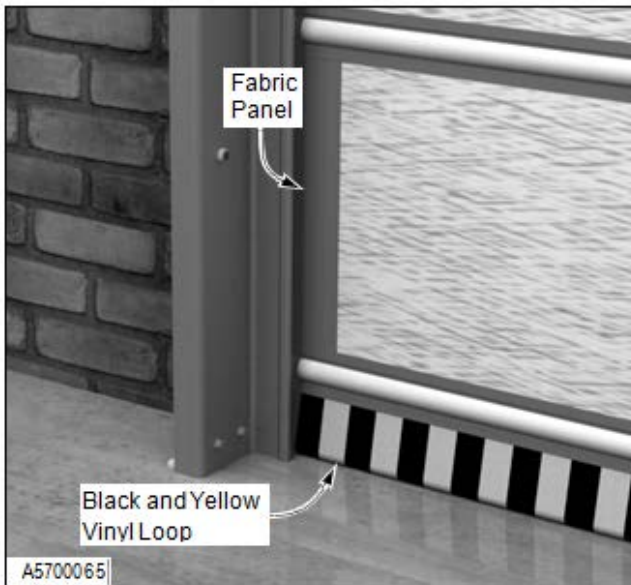


Figure 62

5. Make sure the wind ribs are in place and tightly secured. (See Figure 63)

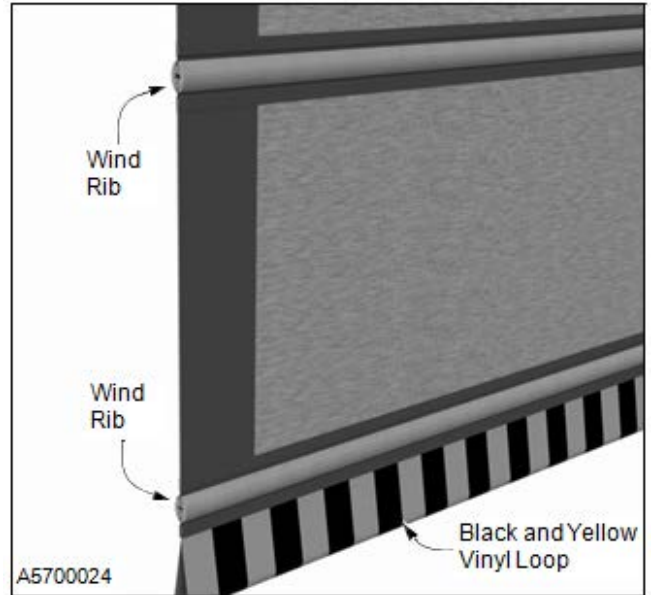


Figure 63

### Bottom Loop Inspection

1. Move the bottom bar of the door to a convenient height for inspection and turn off power.



The disconnect must be in the OFF position and properly locked and tagged before performing the following procedure.

2. Inspect the sealed bladder inside the bottom vinyl loop of the door panel. Replace if the loop is damaged or leaking sand. (See Figure 64.)

**NOTE:** Remove door from service until repairs have been performed. The sealed bladder is filled with sand and is an important integral part for smooth operation.

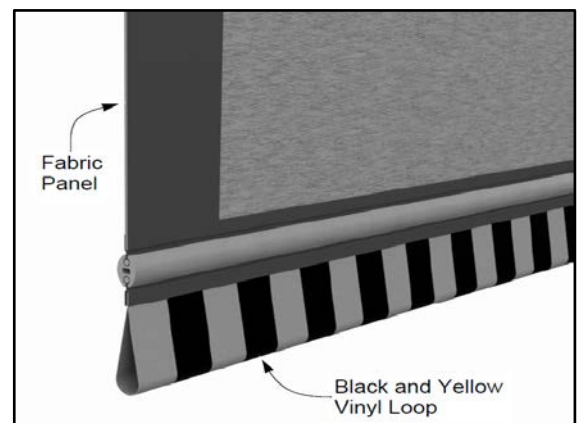


Figure 64

## Brush Seal Inspection

*NOTE: The door seals are mounted on the inside lip of each side column.*

1. Inspect all four door seals on the side columns for wear and tear. Replace as necessary. (See Figure 65)

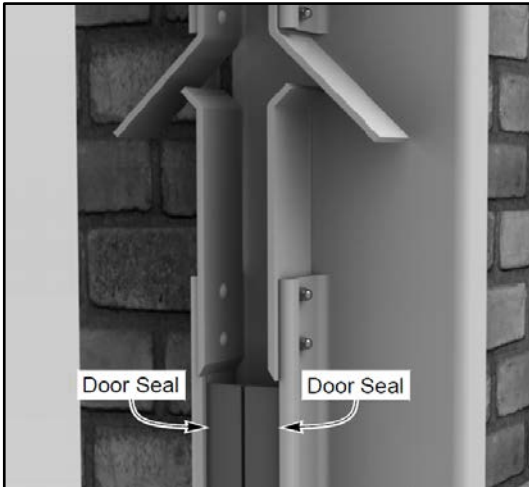


Figure 65

## Door Limit Inspection

### CLOSE LIMIT

With the door in the closed position, check the black and yellow vinyl loop. It should be positioned as shown in figure 66.



**Damage to the vinyl loop or other parts can occur if the door seal is allowed to seal too tightly against the floor. (See Figure 66)**



Figure 66

### OPEN LIMIT

The open limit position should be adjusted so that the door travel allows the bottom bar assembly to stop when it is centered on the outer reinsertion guides. (See Figure 67)

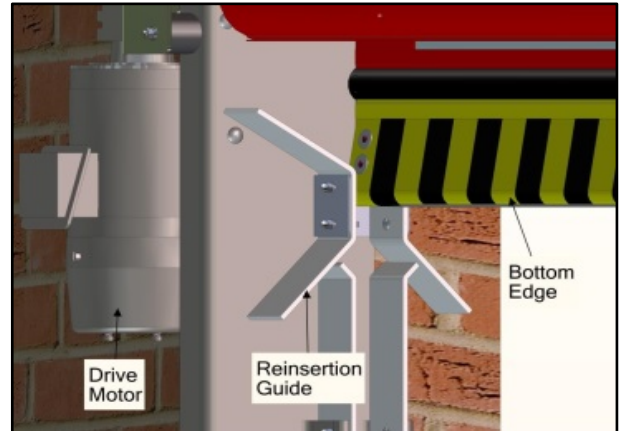


Figure 67

## Motor Brake Inspection

The power drive brake assembly is designed to stop the door panel travel at the locations indicated in the limit switch inspection section. If the limit switches are set properly and the door drifts past the set limits, the brake may require adjustment.

## Bottom Bar Inspection

1. Inspect the hardware to secure the bottom loop assembly. Tighten or replace hardware as required.
2. Inspect the black and yellow vinyl seal for tears and abrasion. Replace any worn or damaged parts as required. (See Figure 68)

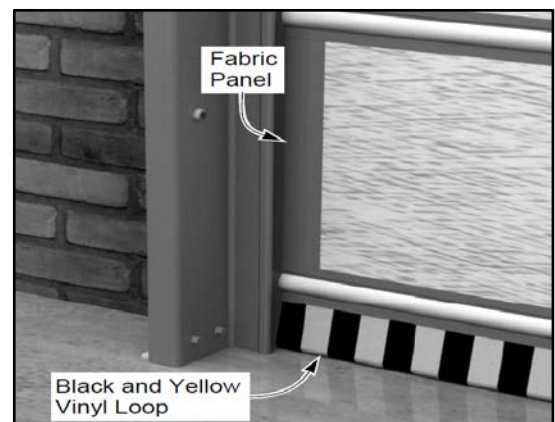


Figure 68

## PLANNED MAINTENANCE—QUARTERLY INSPECTION

### Activator Inspection

1. Inspect all warning and safety labels. All labels should be intact, clean, and clearly legible. Replace any label when necessary.
2. Operate the door five or six complete open and closed cycles with each activator installed with the door. Make any necessary adjustments or repairs. Refer to the associated manual supplied with each activator installed with your door.

Typical activators may include a floor loop. Pull cord, push button, motion detector, radio control, or photo eye. The door open cycle is controlled by the activator. The door close cycle can be controlled by an activator or by a timer internal to the control panel.

### Electrical Connection Inspection



**The disconnect must be in the OFF position and properly locked and tagged before performing the following procedure.**

1. Turn off power to the door.
2. Inspect all electrical connections to the power drive system. All connections must be secure, tight, and dry.
3. Inspect the electrical connections in the junction box located near the head assembly. All connections must be secure, tight, and dry.
4. For proper door operator electrical connection, see the wire diagram or schematic that came with the door.

### Lubrication



**The disconnect must be in the OFF position and properly locked and tagged before performing the following procedure.**

1. Turn off power to the door.
2. Remove the side covers.
3. **Bearing Blocks:** The drum roll is supported by a bearing block located at each end of the drum roll. Each bearing block has a lubrication fitting. (See Figure 69)

The bearings should be lubricated quarterly using a lithium based grease conforming to NLGI grade 2 standard. It should be a medium-viscosity, low-torque rated grease, with an approved operating temperature range of  $-30^{\circ}\text{F}$  to  $200^{\circ}\text{F}$ .

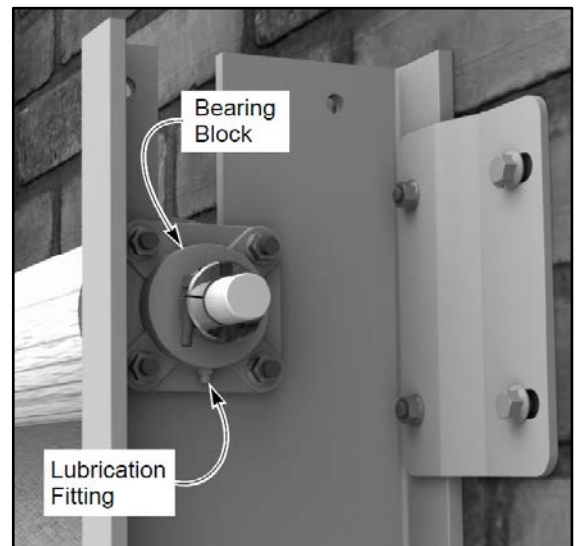


Figure 69

4. **Drive Motor Assembly:** The motor assembly is a sealed unit and doesn't require any lubrication of oil or grease.
5. **Limit Switch Chain:** The limit switch chain should be lubricated with LPS Brand Force 842 Dry Moly Lube (or equal) once installed and as specified in the manual after that to insure proper performance.
6. Install the hood if removed.
7. Restore power to the door.

## MISCELLANEOUS

### PANEL CLEANING

With all adjustments to the door complete, clean both sides of each panel with a general household surface cleaner using a clean, soft cloth.

### PHOTO EYES

#### Operation

Your Rytex Wynd Star MT Door is equipped with a pair of photo eyes for monitoring the front side of the door, an emitter module, and a receiver module. The purpose of these photoeyes is to hold the door open or, if the door is closing, reverse the direction of the door if a person or object breaks the beam of light between the photoeyes. After the obstruction breaking the beam of light is removed:

- If the door was originally opened by an automatic activator, the door will close automatically.
- If the door was originally opened by a non-automatic activator, the door will remain open until it is closed by the non-automatic activator.

*NOTE: The photo eyes are not intended to be used as a door activator and will not open the door when it is closed.*

### FINAL CHECKS

*NOTE: Check the following door systems and components after the door panel has been cycled at least 20 times.*

**Head Assembly:** Check that all mounting hardware is in place and tight.

**Side Columns:** Check that the side columns are plumb and square and that all anchor bolts are tightly secured.

**Photo Eyes:** Check that the photoeyes operate as described in "PHOTOEYES" on page 9 of this manual.

**Activators:** Check to see that the activators operate as specified by the manufacturer.

**Open and Close Limits:** Check open and close limits. See "DOOR LIMITS" starting on page 13 of this manual.

**Caulk:** Ensure that all edges of the jamb and header frames and pullouts are sealed where they meet the wall of the building. Use a high-quality caulk rated for the environment in which the door is installed, as required.

## PARTS LIST – PARTS ORDERING INFORMATION

### PARTS LIST

#### PARTS ORDERING INFORMATION

##### How to Order Parts

1. Identify the parts required by referring to the following pages for part numbers and part descriptions.
2. To place an order, contact your local Rytec representative or the Rytec Technical Support Department at: 1-800-628-1909 or 1-262-677-2058 (fax).
3. To ensure the correct parts are shipped, please include the serial number of your door with the order.

**NOTE:** Your **DOOR SERIAL NUMBER** information can be found on the control box/motor assembly, side columns, hood, and drum assy. (See Figure 70.)

**IMPORTANT:** When installing multiple doors of the same model, verify the serial number in the control panel/motor assembly with the one in the side columns, hood, drum, and head assembly.

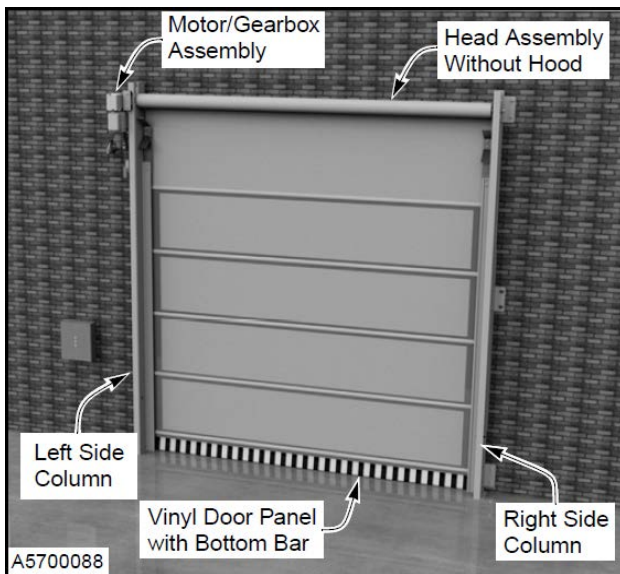


Figure 70

##### Substitute Parts

Due to special engineering and product enhancement, the actual parts used on your door may be different from those shown in this manual.

Also, if a part has been improved in design and bears a revised part number, the improved part will be substituted for the part ordered.

##### Return of Parts

Rytec will not accept the return of any parts unless they are labeled with a Return Merchandise Authorization (RMA) or Incident number.

Before returning any parts, you must first contact the Rytec Technical Support Department and obtain an incident and Return Merchandise Authorization (RMA) number.



### RYTEC TECHNICAL KNOWLEDGE CENTER

At [WWW.Rytecdoors.com](http://WWW.Rytecdoors.com) under the "Customer Support" tab a link to the Rytec Technical Knowledge Center can be found. This knowledge center contains on-line manuals, service bulletins and video presentations of various Rytec models and repair information.

### RYTEC ON-LINE WEBSTORE

Rytec Corporation in partnership with Amazon have developed an on-line webstore for purchasing Rytec replacement parts.

Access to the Rytec webstore is by invitation only. Invitations are processed through the following e-mail address, [webstore@Rytecdoors.com](mailto:webstore@Rytecdoors.com). Please include name and contact information (account holder). All inquiries will be reviewed however, Rytec maintains the authority to grant or deny access to the webstore at all times. The Rytec webstore is open 24/7/365. Parts available on-line require a credit card for purchase. Stocked items routinely ship the same day. The account is strictly for the account holder. All ship to, bill to, and ordering information is the responsibility of the account holder. Currently, over one hundred Rytec parts are available at the on-line store. Shipping rates for the products on line are the lowest rates available.

### RETURNS POLICY FOR ON-LINE WEBSTORE

Customers may return new, unopened items within 30 days of delivery for a full refund.

Items should be returned in their original packaging. The buyer will need to pay for the return shipments; return shipping costs will be refunded if the return is a result of merchant or Amazon error.

All refunds go to the original purchaser. A full refund will be due provided the return is shipped back to RYTEC within the previously specified return period.

Replacements and exchanges are not supported; customers can return their original order for a refund and create a new order for the replacement.

Items classified as hazardous are not returnable. Please contact merchant for issues concerning these items.

Instructions on how to return items:

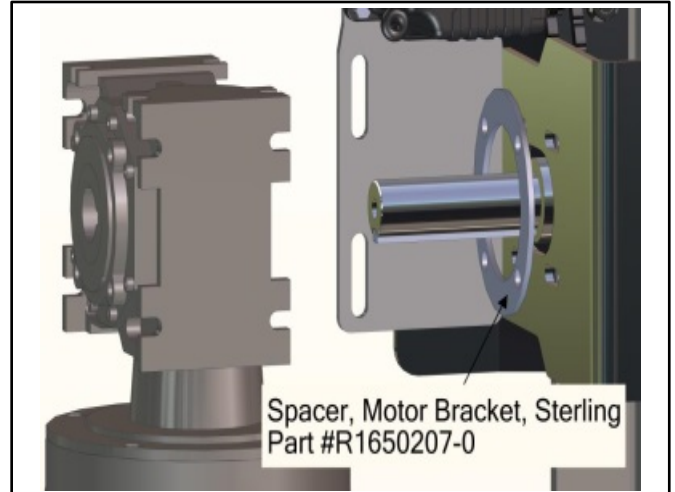
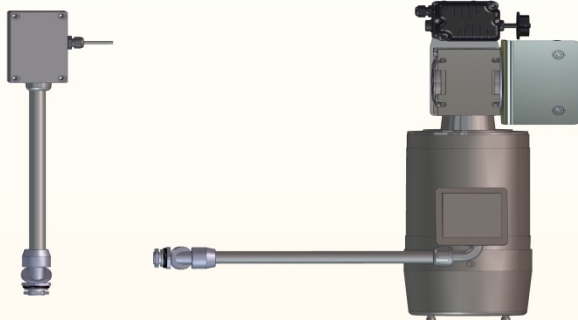
1. Visit return center within your account to create a return merchandise authorization.
2. Print the returns slip and the shipping label.
3. Include the returns slip inside the box and affix the shipping label to the box.
4. Ship package.

Prices subject to change.

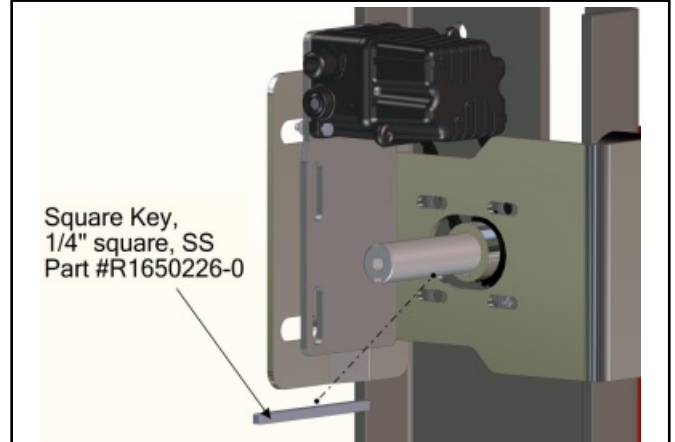
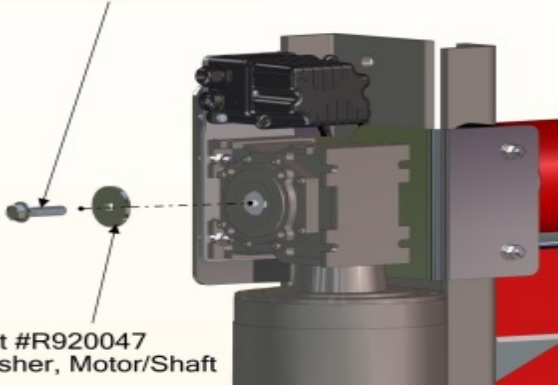
# PARTS LIST—MOTOR ASSEMBLY

## MOTOR ASSEMBLY

Motor Assembly - includes motor, limit box, bracket, cable, seal tight conduit, additional junction box with seal tight conduit for limit switch box. Please provide door serial #  
 Reference part #R1650209-1X for LH Drive  
 Reference part #R1650209-2X for RH Drive



Part #R5550215-0Z04  
 Bolt, 3/8-16 X 1.25, SS



Bolt, 5/16-18 x 1 1/2", SS  
 Part #RS021823

Split Lock Washer,  
 5/16, SS  
 Part #RS554227

Flat Washer, 5/16, SS  
 Part #RS021034

Hex Nut, 5/16, Nylock, SS  
 Part #RS021828

Hex Nut, #10-24, SS, Nylock  
 Part #R5550229-0Z04

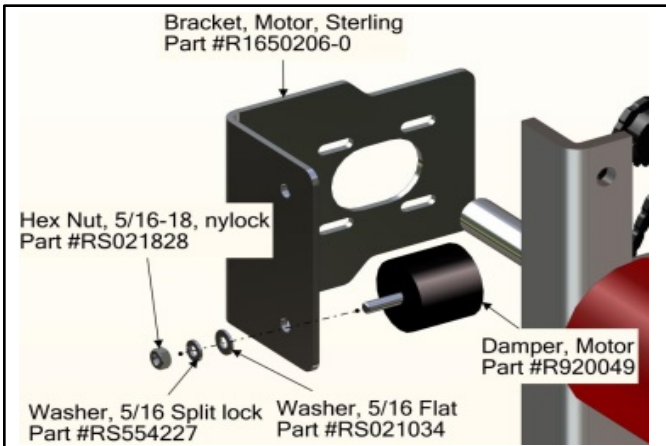
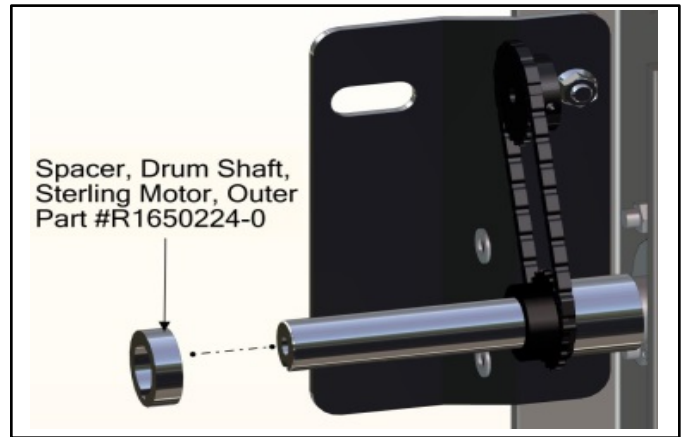
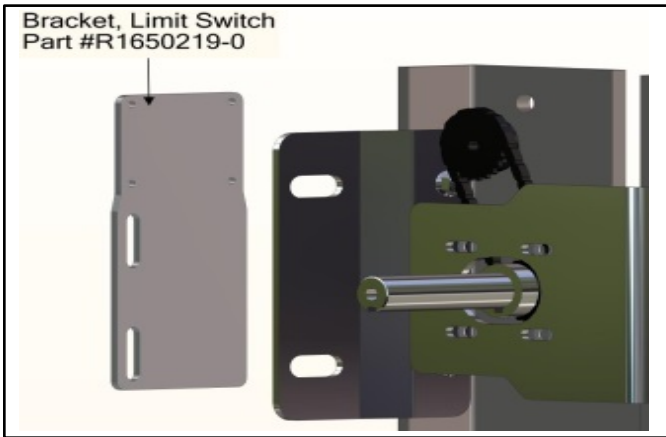
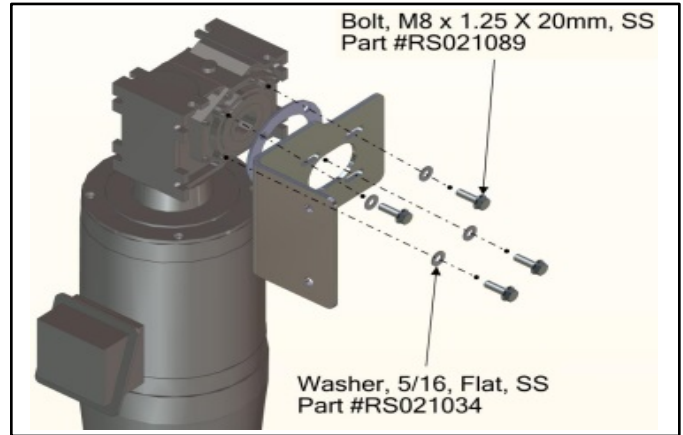
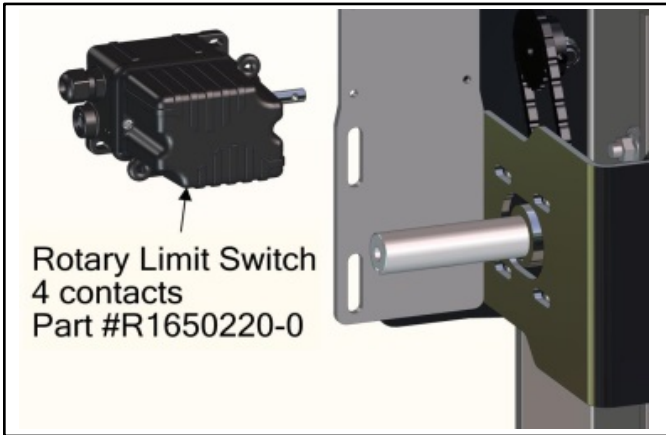
Flat Washer, #10  
 Part #R0555238

Bolt, #10-24 X 1", SS  
 Part #R5550228-0Z04

### ALWAYS INCLUDE SERIAL NUMBER OF DOOR WHEN PLACING ORDER

To ensure you receive the correct parts when placing an order, always include the serial number of your door. Also, due to product enhancement, the actual parts on your door may be different from those shown in this manual.

## PARTS LIST—MOTOR ASSEMBLY

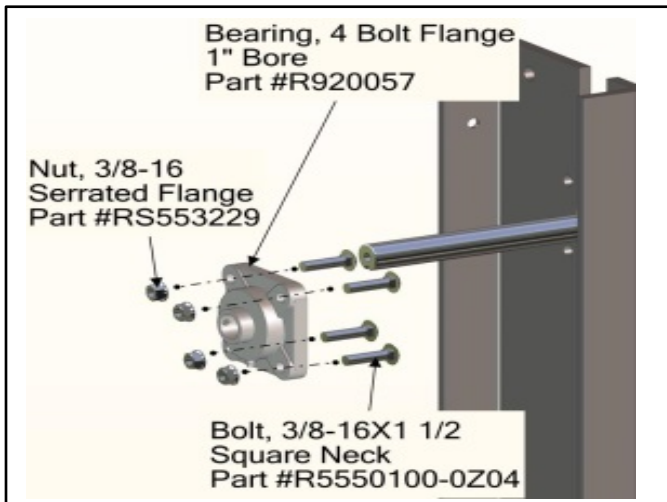
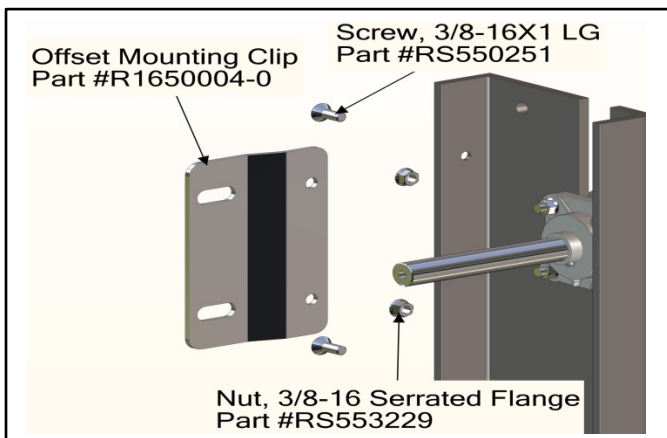
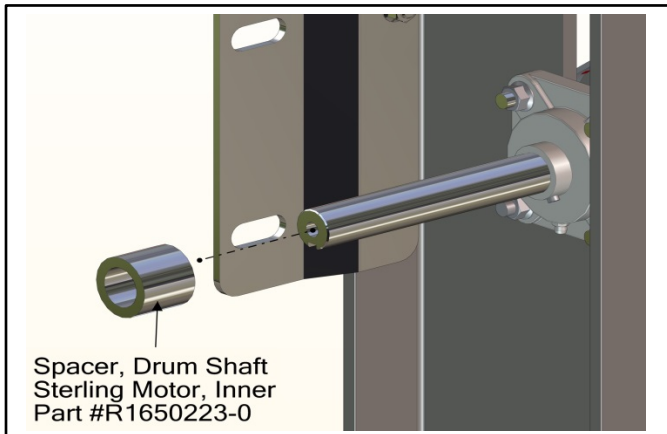


### ALWAYS INCLUDE SERIAL NUMBER OF DOOR WHEN PLACING ORDER

To ensure you receive the correct parts when placing an order, always include the serial number of your door. Also, due to product enhancement, the actual parts on your door may be different from those shown in this manual.

## PARTS LIST—MOTOR ASSEMBLY

### MOTOR ASSEMBLY



#### **ALWAYS INCLUDE SERIAL NUMBER OF DOOR WHEN PLACING ORDER**


To ensure you receive the correct parts when placing an order, always include the serial number of your door. Also, due to product enhancement, the actual parts on your door may be different from those shown in this manual.

**PARTS LIST—SIDE COLUMN ASSEMBLY**

**PARTS LIST—SIDE COLUMN ASSEMBLY**

Left Hand Side Column Assembly  
Please provide door serial # for order, reference Part #R1650021-1X

NOTE: These brackets are not standard for all doors, used for pull out doors. If required order part #R1650004-0



Right Hand Side column Assembly  
Please provide door serial # for order, reference Part #R1650021-2X



Offset Mounting Bracket  
Part #R1650004-0

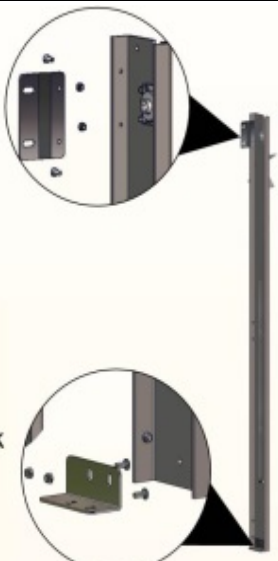
Hardware for mounting  
Screw, 3/8-16X1 LG  
Part #RS550251

Nut, 3/8-16 Serrated Flange  
Part #RS553229

Bottom Mounting Angle  
Part #R1650002-0

Hardware for mounting  
Screw, 3/8-16X1, Square Neck  
Part #RS021824

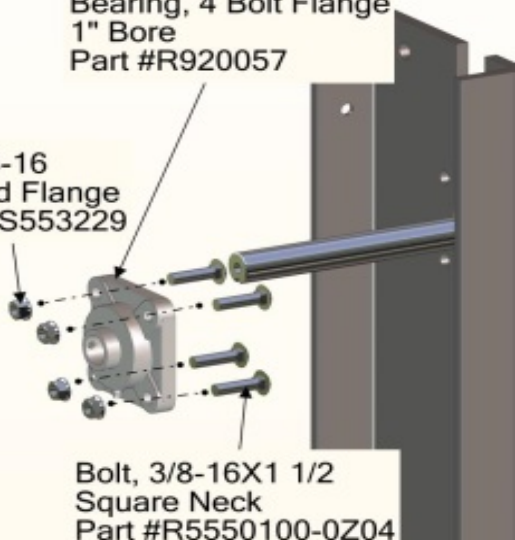
Nut, 3.8-16 Serrated Flange  
Part #RS553229



Bearing, 4 Bolt Flange  
1" Bore  
Part #R920057

Nut, 3/8-16  
Serrated Flange  
Part #RS553229

Bolt, 3/8-16X1 1/2  
Square Neck  
Part #R5550100-0Z04



Refeed Clip, Top Front  
Part #R1650018-0

Hardware to attach Clips and bracket  
Acorn Nut, 1/4-20  
Part #RS021590

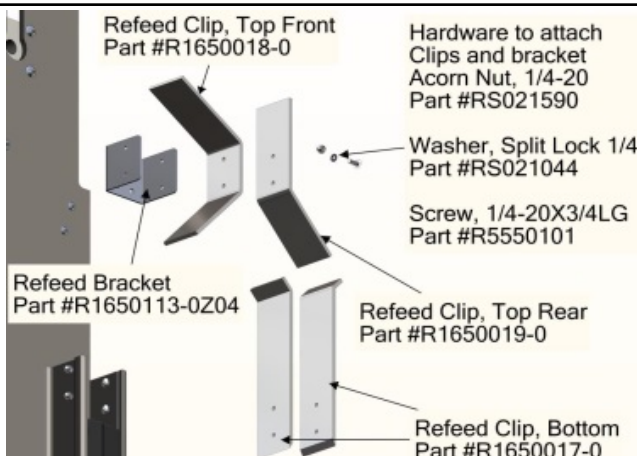
Washer, Split Lock 1/4  
Part #RS021044

Screw, 1/4-20X3/4LG  
Part #R5550101


Refeed Bracket  
Part #R1650113-0Z04

Refeed Clip, Top Rear  
Part #R1650019-0

Refeed Clip, Bottom  
Part #R1650017-0



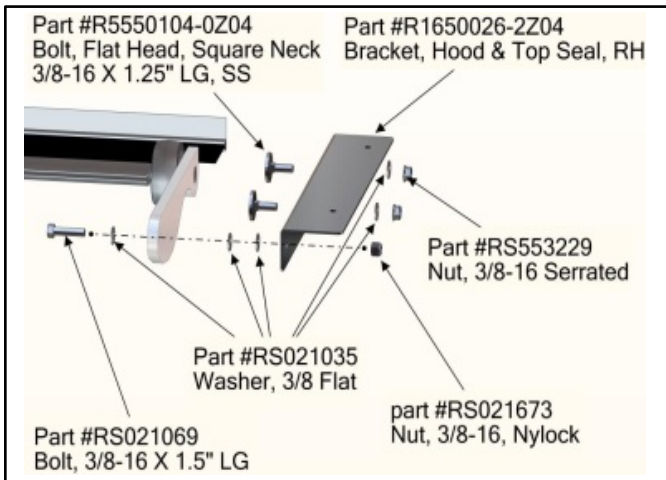
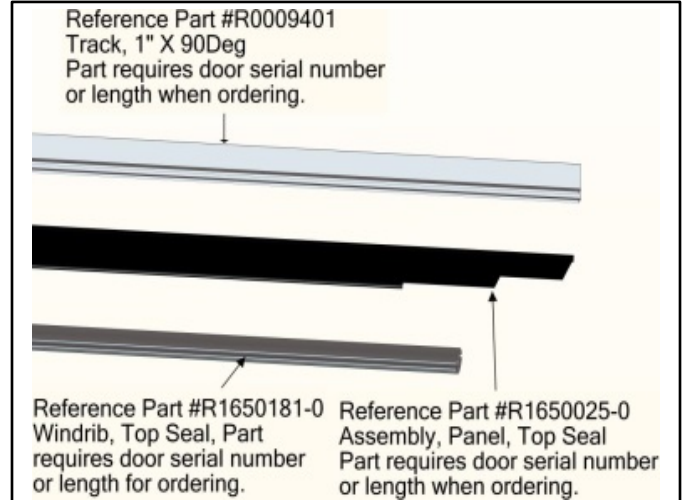
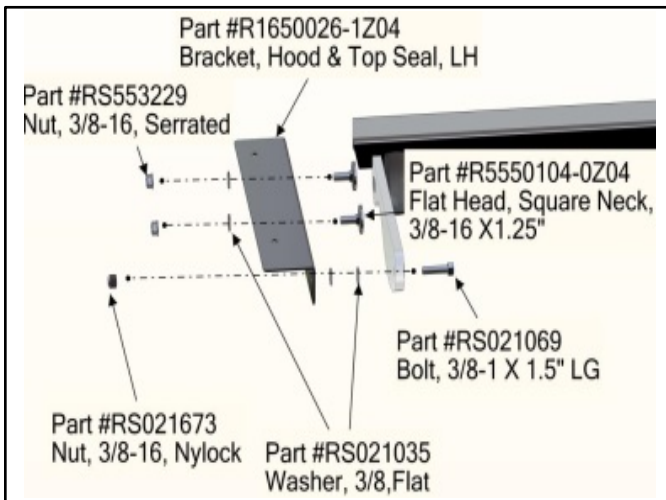
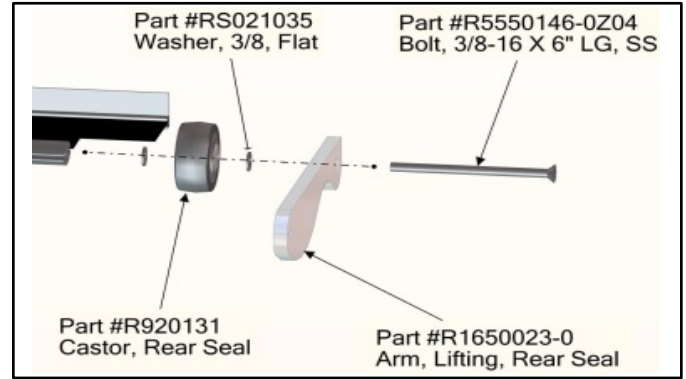
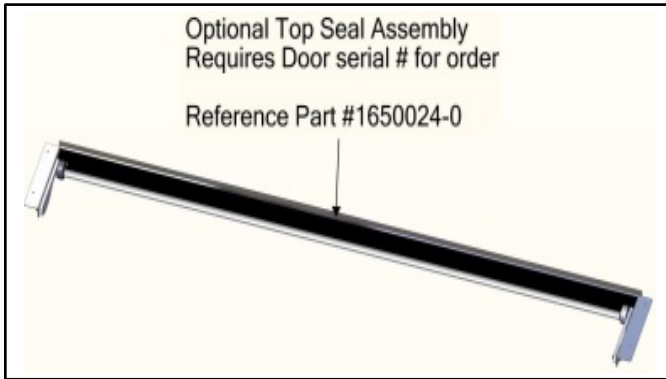
Brush, 1 1/2"  
Part requires door serial #  
or length for order.  
Reference Part #R0009009



**ALWAYS INCLUDE SERIAL NUMBER OF DOOR WHEN PLACING ORDER**  
To ensure you receive the correct parts when placing an order, always include the serial number of your door. Also, due to product enhancement, the actual parts on your door may be different from those shown in this manual.

## PARTS LIST—HEAD ASSEMBLY

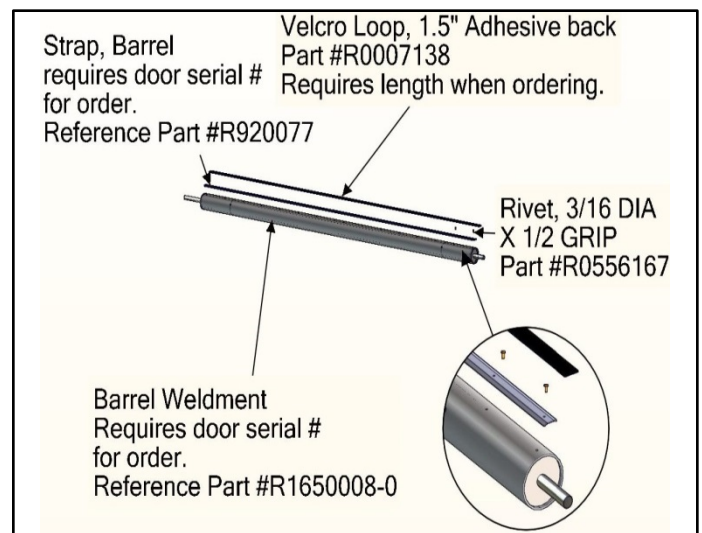
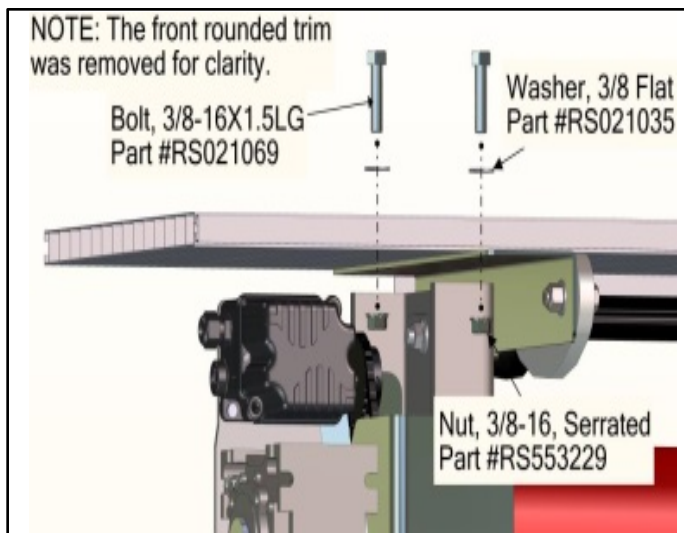
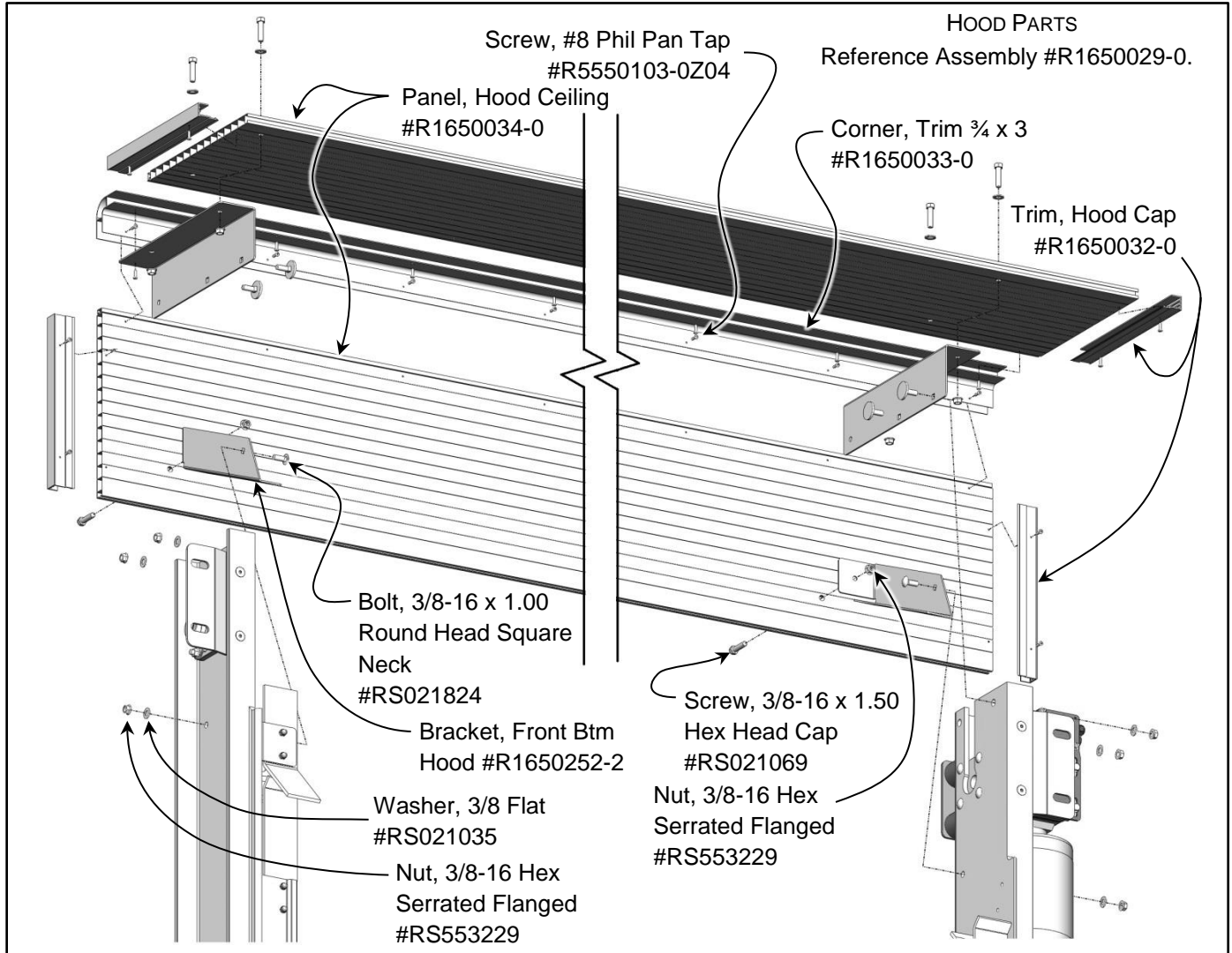
### HEAD ASSEMBLY TOP SEAL



**ALWAYS INCLUDE SERIAL NUMBER OF DOOR WHEN PLACING ORDER**

To ensure you receive the correct parts when placing an order, always include the serial number of your door. Also, due to product enhancement, the actual parts on your door may be different from those shown in this manual.

## HEAD ASSEMBLY HOOD & DRUM

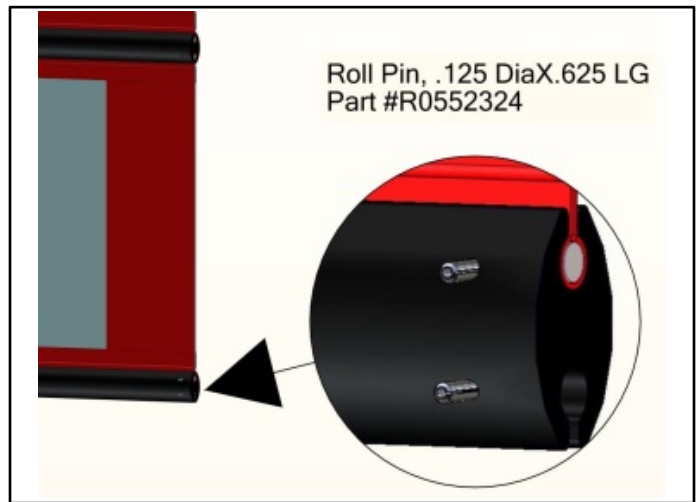
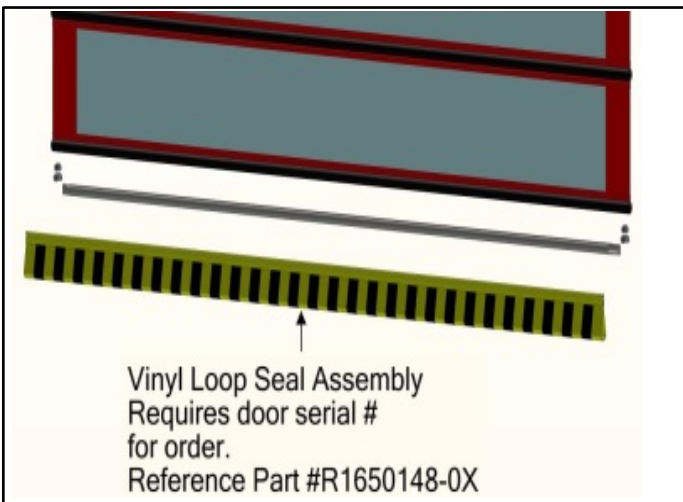
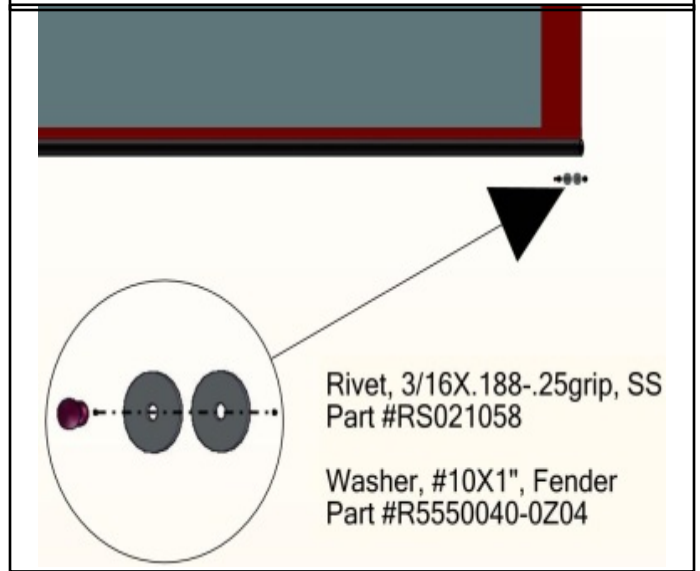
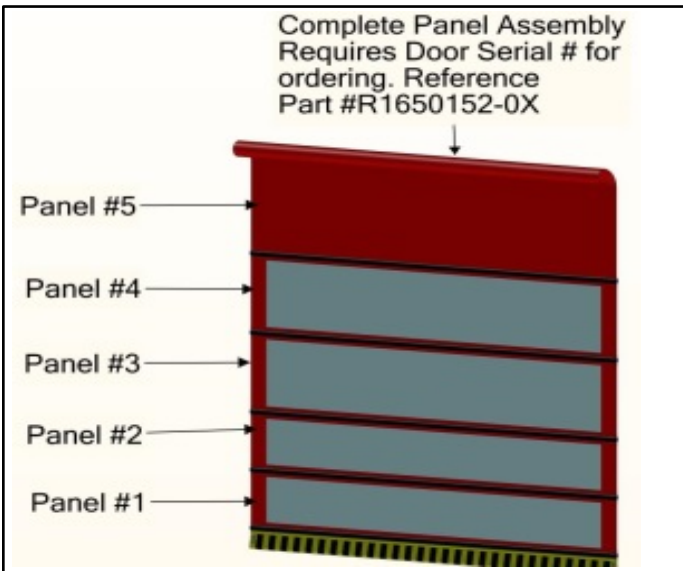
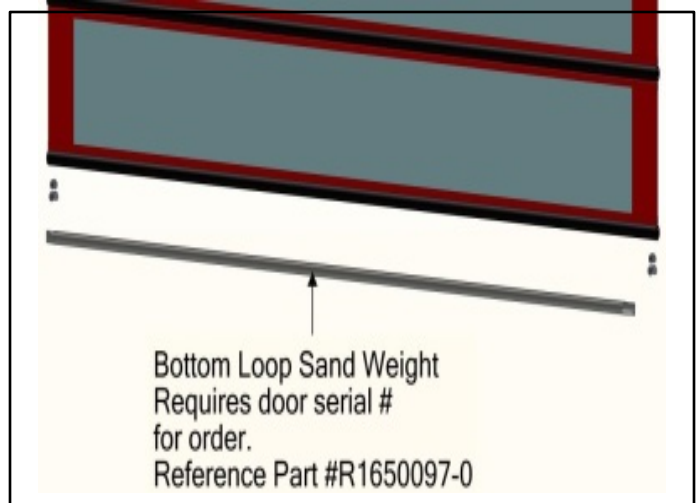
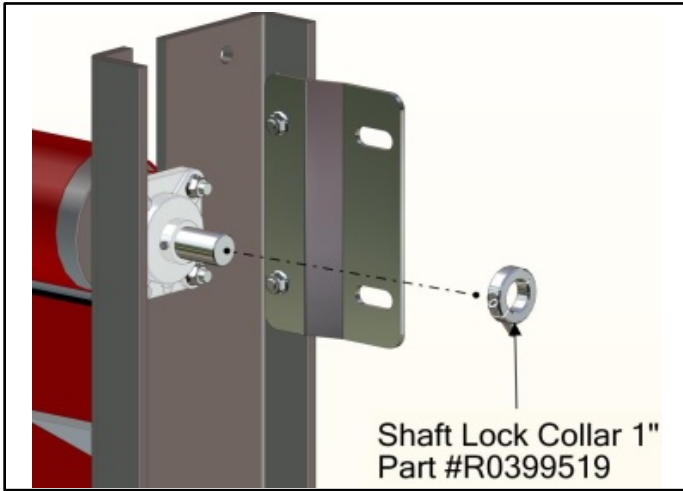


### ALWAYS INCLUDE SERIAL NUMBER OF DOOR WHEN PLACING ORDER

To ensure you receive the correct parts when placing an order, always include the serial number of your door. Also, due to product enhancement, the actual parts on your door may be different from those shown in this manual.

# PANEL ASSEMBLY

## PANEL ASSEMBLY

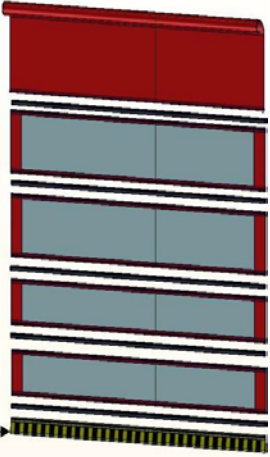


**ALWAYS INCLUDE SERIAL NUMBER OF DOOR WHEN PLACING ORDER**  
To ensure you receive the correct parts when placing an order, always include the serial number of your door. Also, due to product enhancement, the actual parts on your door may be different from those shown in this manual.

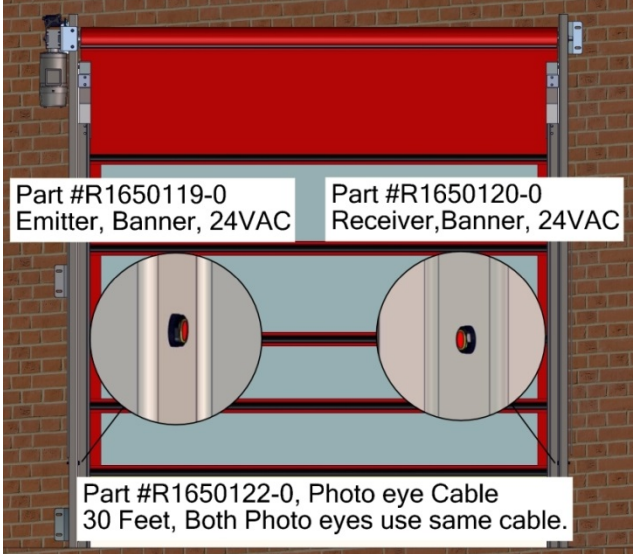


PHOTO EYES

Individual panels are available  
Requires door serial # for order.  
Panels counted from bottom after  
the vinyl loop. This example is a 5  
panel door.



Vinyl Loop Seal Assembly  
Requires door serial #  
for order.  
Reference Part #R1650097-0



Part #R1650119-0  
Emitter, Banner, 24VAC

Part #R1650120-0  
Receiver, Banner, 24VAC

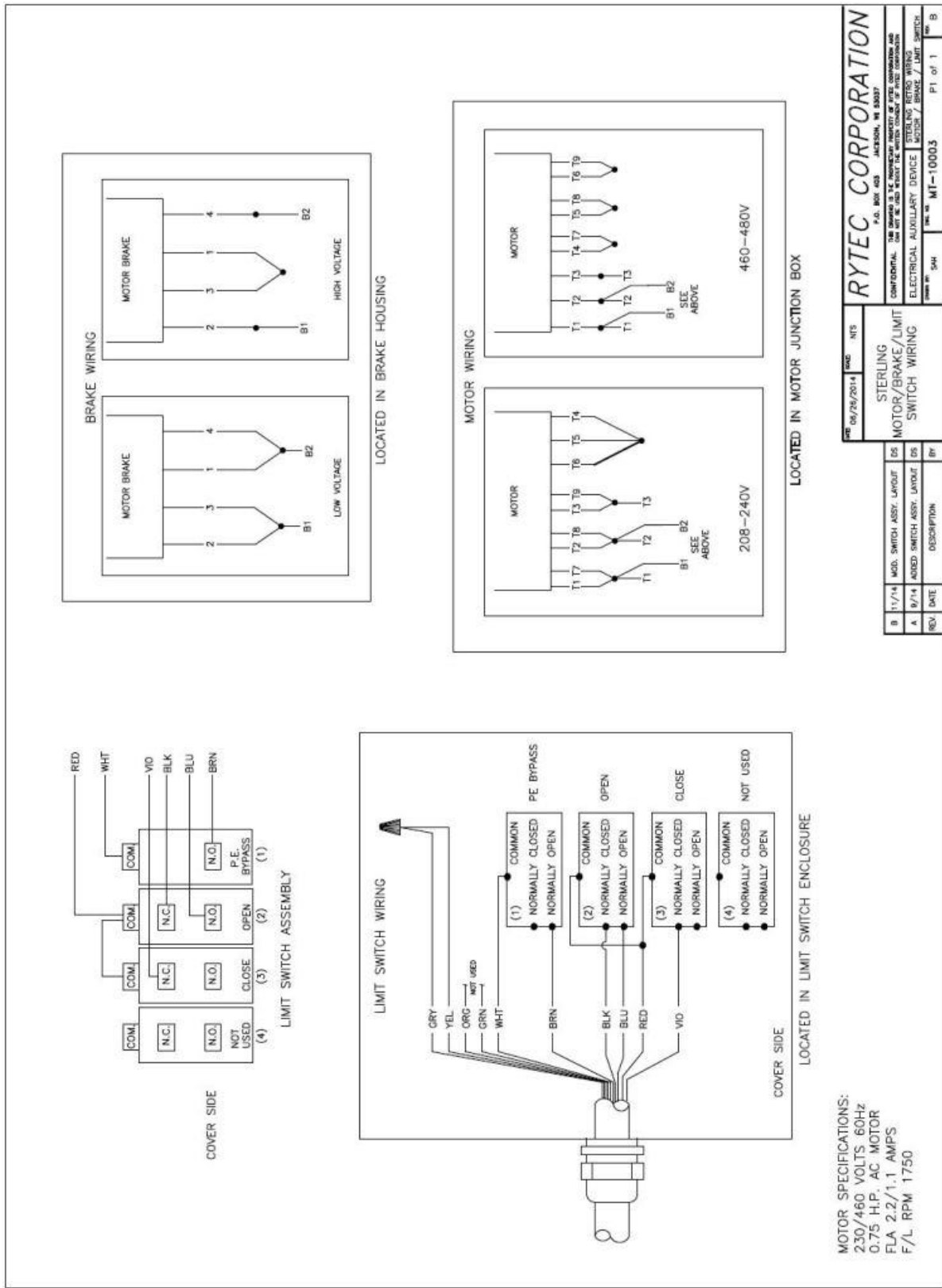
Part #R1650122-0, Photo eye Cable  
30 Feet, Both Photo eyes use same cable.

**ALWAYS INCLUDE SERIAL NUMBER OF DOOR WHEN PLACING ORDER**

To ensure you receive the correct parts when placing an order, always include the serial number of your door. Also, due to product enhancement, the actual parts on your door may be different from those shown in this manual.

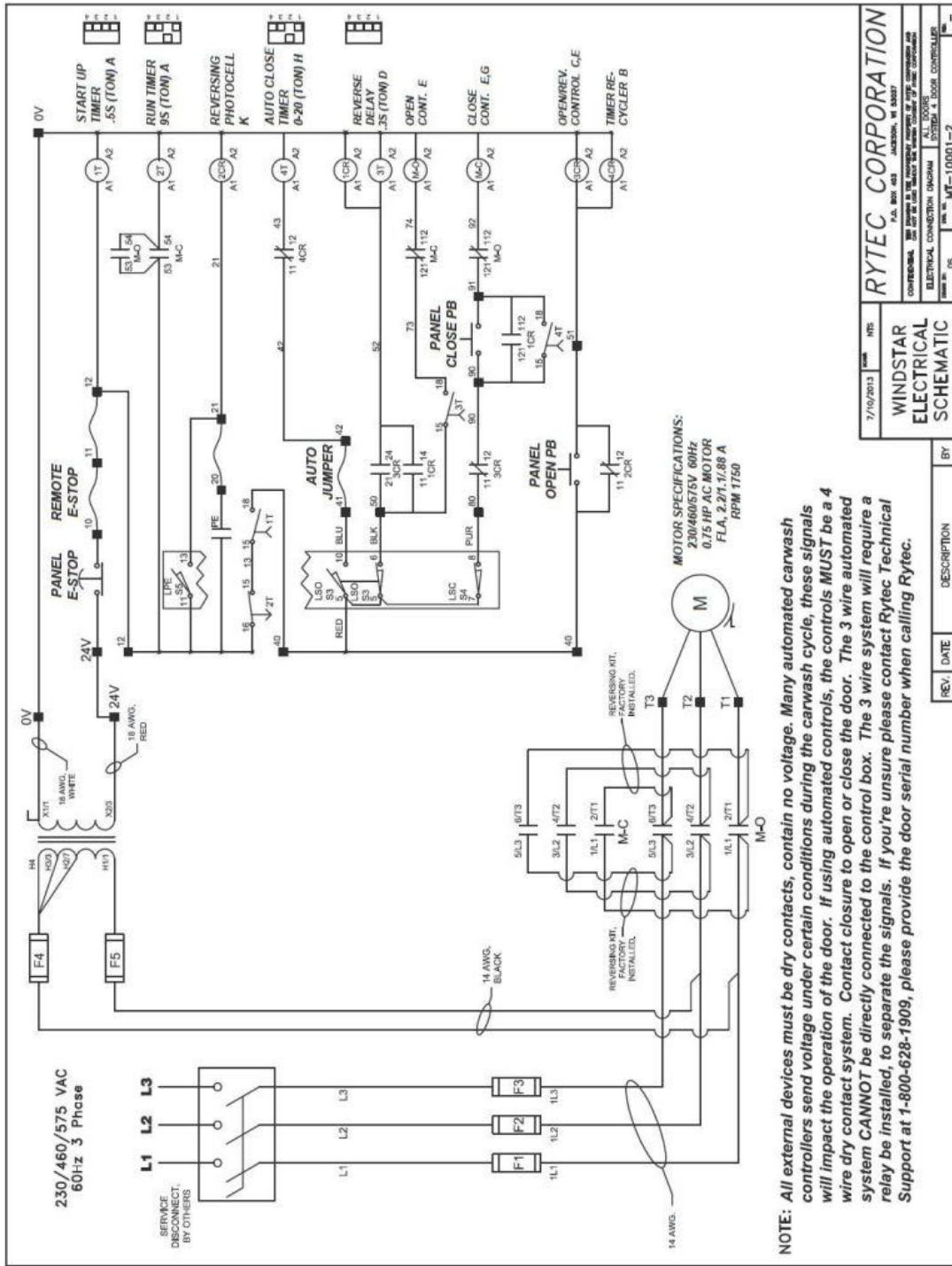
# ELECTRICAL SCHEMATIC

## ELECTRICAL SCHEMATIC – LIMITS & MOTOR



**ELECTRICAL SCHEMATICS ABOVE PROVIDED AS REFERENCE ONLY**  
 Please refer to electrical schematics shipped in the control panel for your specific door.

ELECTRICAL SCHEMATIC - CONTROL PANEL



7/10/2013  
 WINDSTAR ELECTRICAL SCHEMATIC  
 RYTEC CORPORATION  
 P.O. BOX 483  
 JACKSON, WI 53007  
 ELECTRICAL CONNECTION DIAGRAM  
 ALL TOOLS  
 DATE: 06  
 DRAWING NO: MT-10001-2

REV.	DATE	DESCRIPTION	BY

**EXTERNAL 3 & 4 WIRE CONTROLS NOTE:**

All external devices **MUST** be dry contacts, contain no voltage. Many automated carwash controllers send voltage signals under certain conditions during the carwash cycle. These signals will impact the operation of the door. If using automated controls, the controls **MUST** be a 4 wire dry contact system. Contact closure to open or close the door. The 3 wire automated system **CANNOT** be directly connected to the control box. The 3 wire system will require a relay be installed, to separate the signals. If you're unsure please contact Rytec Technical Support at 1-800-628-1909, please provide the door serial number when calling Rytec.

**ELECTRICAL SCHEMATICS ABOVE PROVIDED AS REFERENCE ONLY**  
 Please refer to electrical schematics shipped in the control panel for your specific door.

ELECTRICAL SCHEMATIC

ELECTRICAL SCHEMATIC - CONTROL BOX PARTS

MAIN FUSE SCHEDULE

VOLTAGE	FLA	RECOMMENDED FUSE	RYTEC NO
208-230	3.43	7.0 AMP, TYPE CC OR EQUAL	0-011-648
460-575	1.7/1.4	3.0 AMP, TYPE CC OR EQUAL	0-011-075

CONTROL TRANSFORMER FUSE SCHEDULE

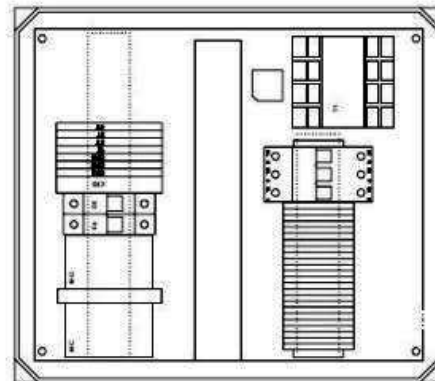
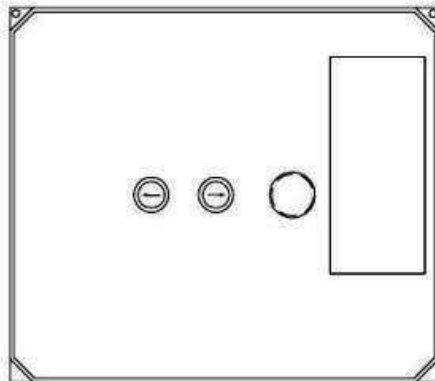
VOLTAGE	FLA	RECOMMENDED FUSE	RYTEC NO
208-230	.3	.6 AMP, TYPE CC OR EQUAL	0-011-010
460-575	.15	.3 AMP, TYPE CC OR EQUAL	0-011-1146

EXTERNAL COMPONENTS SCHEDULE

QTY	ITEM	DESCRIPTION	RYTEC NO
1	ENCLOSURE	ENCLOSURE, NON-METALLIC, NEMA T4	0-011-5029
1 EA	PB-1, PB-2	PUSH BUTTON, MOM, 22mm	0-011-5030
2	CON-N/O	CONTACT BLOCK, N/O	0-011-5031
1	PB-ESTP	PUSH BUTTON, MNT, 22mm	0-011-5034
1	CON-N/C	CONTACT BLOCK, N/C	0-011-5035
1	LGD-STP	LEGEND PLATE, STOP	0-011-5036
1	LGD-UP	LEGEND-UP ARROW	0-011-5032
1	LGD-DN	LEGEND-DOWN ARROW	0-011-5033

INTERNAL COMPONENTS SCHEDULE

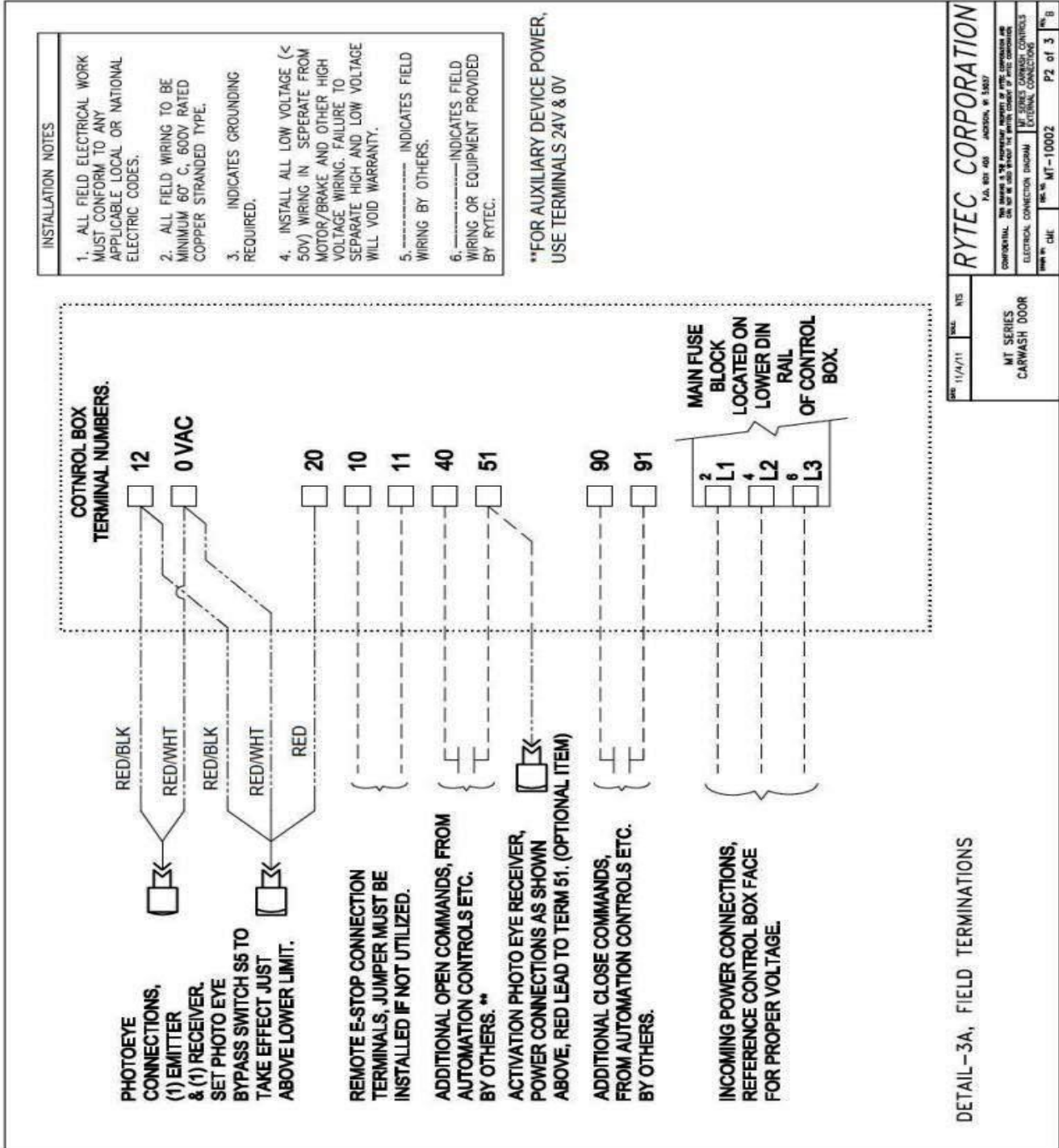
QTY	ITEM	DESCRIPTION	RYTEC NO
1	SUB PLATE	SUB PLATE, 14 X 12	0-011-5011
2	GUARD, T1	FINGER GUARD, TRANSFORMER TERMINALS	0-011-5013
1 EA	MO, MC	CONTACTOR, 9A, 24VAC COIL, 1-N/O AUX.	0-011-5014
1	INTERLOCK	INTERLOCK, MECH/ELEC	0-011-5015
1	REV KIT	REVERSING WIRE KIT	0-011-5016
2	AUX CONTACT	AUXILIARY CONTACT	0-011-5017
1	FS Hldr 3	FUSE HOLDER, 3 POLE, 600V	0-011-5018
2	FS Hldr 2	FUSE HOLDER, 2 POLE, 600V	0-011-1025
23	TB-GRY	TERMINAL BLOCK, GRAY, 3 POS.	0-011-5019
1	TB-GND	TERMINAL BLOCK, GRN, 3 POS	0-011-5020
3	TB-BAR	TERMINAL BLOCK, BARRIER	0-011-5021
2	TB-END	TERMINAL BLOCK, END-STOP	0-011-5022
1	TB-JMP	TERMINAL BLOCK, JUMPER	0-011-5023
1 EA	T1, 2T, 3T, 4T	TIMER BASE, 24VAC, SPDT	0-011-5024
1 EA	CR1, CR2, CR4	RELAY BASE, 24VAC, SPDT	0-011-5028
7	CONTACTS, TMR	TIMER CONTACT MODULES, USE IN CR# AND #T	0-011-5000
1	CR3	CONTROL RELAY, DPDT, 24VAC	0-011-5025
1	RECT	RECTIFIER, 25A, FULL WAVE	0-011-5026
1	T1	TRANSFORMER, 50VA, MULTI TAP, 208-460V	0-011-5012
1	T1-600V	TRANSFORMER, 50VA, MULTI TAP, 600V ONLY	0-011-5054
1	GUARD-600V	FINGER GUARD, FOR USE WITH 0-011-5024	0-011-5055



MOTOR SPECIFICATIONS  
 230/460V 60HZ  
 0.75 HP AC MOTOR  
 FLA, 2.2/1.1A  
 RPN 1750

ELECTRICAL SCHEMATICS ABOVE PROVIDED AS REFERENCE ONLY  
 Please refer to electrical schematics shipped in the control panel for your specific door.

ELECTRICAL SCHEMATIC - PHOTOEYES



**EXTERNAL 3 & 4 WIRE CONTROLS NOTE:**

All external devices **MUST** be dry contacts, contain no voltage. Many automated carwash controllers send voltage signals under certain conditions during the carwash cycle. These signals will impact the operation of the door. If using automated controls, the controls **MUST** be a 4 wire dry contact system. Contact closure to open or close the door. The 3 wire automated system **CANNOT** be directly connected to the control box. The 3 wire system will require a relay be installed, to separate the signals. If you're unsure please contact Rytec Technical Support at 1-800-628-1909, please provide the door serial number when calling Rytec.

**ELECTRICAL SCHEMATICS ABOVE PROVIDED AS REFERENCE ONLY**  
 Please refer to electrical schematics shipped in the control panel for your specific door.

**NOTES:**

---



